

Arado Ar. (E) 555

Anfang 1944 begannen auf Anordnung des Technischen Amtes des Reichsluftfahrtministeriums (RLM) bei den Arado-Werken in Landeshut/Schlesien die Entwurfsarbeiten für ein Langstrecken- und Hochgeschwindigkeitsflugzeug. Nach einer Besprechung am 20. April 1944 legte man sich auf ein Nurlüglflugzeug fest das eine Reichweite von 4800 km und eine Höchstgeschwindigkeit von 860 km/h erreichen sollte. Als Bombenlast wurden verschiedene Abwurfaffen bis zu einer maximalen Zuladung von 4000 kg verlangt. Als Defensivbewaffnung wurden je 2 Rheinmetall-Borsig MK 103, Kaliber 30 mm, vorn in den Tragflächen-vorderkanten, sowie je 2 Maser MG 151/20, Kaliber 20 mm, in einem Drehturm auf der Rumpfoberseite und -unterseite vorgesehen. Die Steuerung der Drehtürme erfolgte durch ein ausfahrbares Periskop im druckbelüfteten Besatzungsraum, der bis zu drei Mann aufnehmen sollte. Als Hauptfahrwerk war ein, nach innen einziehbares, Tandem - Fahrwerk mit jeweils 4 Laufrädern pro Seite und ein kleineres Bugfahrwerk mit zwei Laufrädern vorgesehen. Der Antrieb bestand aus 6 BMW 003A Jet-Triebwerken die auf dem Rumpfrücken, paarweise versetzt, auf gleicher Höhe nebeneinander angeordnet waren. Die gleichen Triebwerke wurden auch später im Serienbau der Arado Ar 234C und der Heinkel He 162 verwendet. Am 23. Dezember 1944 wurden, wegen der Kriegslage und fehlender Rohstoffe, auf Anweisung des Reichsluftfahrtministeriums alle weiteren Arbeiten eingestellt.

Heute gilt die Arado Ar 555 zusammen mit der Go 229, von der noch eine Maschine im Smithsonian Institution in Washington D.C. erhalten ist, als die erste Generation der Stealth-Flugzeuge. So erinnert die Northrop B-2 Spirit in vielen Bereichen an die Ar 555. So zum Beispiel die Ausführung der Fahrwerke und ihre ähnlichen überdimensionierten Hauptfahrwerkstrüme, der Besatzungsraum und die Anordnung der Triebwerke. Wie hervorragend die Stealth-Eigenschaften dieser Flugzeuge waren hat Northrop 2009 im Auftrag des National Geographic Channel selbst durch einen großen Radarvergleichstest belegt. Eine in Originalgröße (1:1) gebaute Go 229 wurde im Northrop Test Center auf einen Pylon montiert und mit Radargeräten ausgemessen. Dabei ergaben sich um mehr als 20% geringere Reflexionseigenschaften gegenüber konventionellen Flugzeugen, was die Vorwarnzeiten um mehr als die Hälfte reduziert hätte. (Nur noch 8 statt 19 Minuten) Als „Amerika-Bomber“ - wie sie oft bezeichnet wird - wäre die Arado Ar 555 nicht geeignet gewesen. Bei einer Reichweite von „nur“ 5000 Kilometer hätte es kaum bis nach New York gereicht - die Entfernung Frankfurt/Main - New York beträgt 6200 km.

Technische Daten:

Spannweite	20.90 m
Länge	15.85 m
Höhe	5.00 m
Motoren	6 x BMW 003A
Leistung	je 800 kp
Leergewicht	15 680 kg
Startgewicht	24 000 kg
Landegeschwindigkeit	165 km/h
Höchstgeschwindigkeit	860 km/h
Reisegeschwindigkeit	620 km/h
Dienstgipfelhöhe	15 000 m
Reichweite	4 800 km
Bewaffnung	2 x MK 103 Tragflächenvorderkante 2 x MG 151/20 Drehturm 2 x MG 151/20 in Drehturm unter Rumpf
Bombenladung	4 000kg
Besatzung	3 Mann

Arado Ar. (E) 555

Early in 1944 on a directive from the Technical Office of the Imperial Aviation Ministry, the Arado plant in Landshut/Silesia began design of an aircraft with the capabilities of high-speed and long-range. After a meeting on 20 April 1944, it was decided to use the flying wing concept. The aircraft should achieve a range of 4800 km (2980 miles) and a top speed of 860 km/h (534 mph). As the Bomb-load, a variety of weapons were to be carried up to a maximum payload of 4000 kg (8820 lbs). For the defensive armament it was envisaged to install two Rheinmetall-Borsig 30 mm calibre MK 103's in the leading edges of the wing and 2 twin Maser 20 mm calibre MG 151/20's in turrets above and below the fuselage. The turrets were to be controlled via a retractable periscope from a pressure-ventilated crew room which was to accommodate up to three crewmen. As the main undercarriage an inwardly retractable tandem arrangement with 4 wheels per side was envisaged with a smaller nose gear with two wheels. The power unit consisted of 6 BMW 003A jet engines mounted on the upper fuselage. They were located in pairs, placed side by side with the outer pairs displaced slightly aft. Similar engines were also used later in the mass production of the Arado Ar 234C and Heinkel He 162. On 23 December 1944 due to the War and the lack of raw materials, all further work was discontinued on instructions from the Imperial Aviation Ministry. Today, the Arado Ar 555 together with the Go 229, another aircraft preserved in the Smithsonian Institute in Washington DC, is considered to be a first generation Stealth Aircraft. The Northrop B-2 Spirit is similar to the Ar 555 in many of its features. The undercarriage design for example, with its over-dimensioned main gear doors, the crew compartment and the engine arrangement. In 2009 on behalf of the National Geographic Channel, Northrop itself tested how good the stealth characteristics of these aircraft were in an extensive radar comparison test. At the Northrop Test Centre a Go 229 was built to the original size (1:1), mounted on a pylon and its radar returns were measured. The results indicated more than 20% lower reflection rates when compared with conventional aircraft, which would have reduced detection times by more than half (Only 8 instead of 19 minutes). As the „America Bomber“ - as it is often referred to - the Arado Ar 555 would not have been suitable. With a range of „only“ 5000 km (3100 miles) it would not have reached New York - the distance between Frankfurt/Main and New York is 6200 km (3850 miles).

Technical Data:

Wingspan	20.90 m (68ft 6ins)
Length	15.85 m (52ft 0ins)
Height	5.00 m (16ft 5ins)
Engines	6 x BMW 003A
Power	each 800 kp
Empty Weight	15 680 kg (34574 lbs)
Take-off Weight	24 000 kg (52920 lbs)
Landing Speed	165 km/h (102 mph)
Maximum Speed	860 km/h (534 mph)
Cruising Speed	620 km/h (385 mph)
Service Ceiling	15 000 m (49200 ft)
Range	4 800 km (2980 miles)
Armament	2 x MK 103 Wing Leading Edge 2 x MG 151/20 Rotating Turret 2 x MG 151/20 in a Rotating Turret under the Fuselage
Bomb Load	4000 kg (8820 lbs)
Crew	3

Form hergestellt und im Eigentum von Revell GmbH & Co. KG. Widerrechtliche Nachahmungen werden gerichtlich verfolgt.
Ce produit est propriété de la société Revell GmbH & Co. KG. Toute utilisation ou duplication frauduleuse fera l'objet de poursuites en justice.
Modelado y en propiedad de Revell GmbH & Co. KG. Imitaciones ilícitas serán perseguidas por la ley.
Forma prodotta dalla Revell GmbH & Co. KG. e di proprietà della stessa impresa. La quale procederà legalmente contro ogni imitazione abusiva.
Mall on Revell GmbH & Co. KG. valmistama ja omaisuutena. Laittomaan kopiointiin tullaan puuttamaan oikeudellisin toimin.
Formen er produsert og er av Revell GmbH & Co. KG. Etterfigning uten tillatelse vil bli gjenstand for rettslig forfølgelse.
Produkcia i prawa własności firmy Revell GmbH & Co. KG. In egjalne podrabianie jest zabron-one pod dotychczasową nazwą.
Model Revell GmbH & Co. KG. firmasının mülkiyeti altında imal edilmiştir. Kanuna aykırı taklidler mahkemeye takip edilecektir.
A forma ehtilältaja és a tulajdonjog betekosa a Revell GmbH & Co. KG. A jogellenes utánzatokat az írásbeli bírósággal üldözök. Üldözök.

Mould manufactured by and property of Revell GmbH & Co. KG. illegal imitations are subject to prosecution.
Vorm vervaandigt door en eigendom van Revell GmbH & Co. KG. Onrechtmatige nabootsingen worden gerechtelijk vervolgd.
Formas produzidas e de propriedade da Revell GmbH & Co. KG. Cópias não autorizadas serão processadas juridicamente como determinado na lei.
Modellen tillverkad av och tillhör Revell GmbH & Co. KG. All kopiering beivras enligt lagen om upphovsrätt.
Formen er fremstillet af Revell GmbH & Co. KG. som også her ejendommen. Lovstridige efterfigninger sagsøges.
Modela dizajnirana i vlastnosti tvrtkosti Revell GmbH & Co. KG. Prerabotkane kopije bez odobrenja predstavlja u stvarnom porijeklu.
H výrobky vlastnosti firmy Revell GmbH & Co. KG. On poravných kopijev bez autorizovaného dovolenia.
Tva byl vyroben linnou Revell GmbH & Co. KG. a je její vlastností. Vrahi nezákonných napodobeninán se bude posturovat souduí cestou.
Forma je proizvedene in je vlasništvo Revell GmbH & Co. KG. Neovlađene kopije bodo pravno kažnjene.

Benötigte Farben / Used Colors

Benötigte Farben
Required colours

Peintures nécessaires
Benodigde kleuren

Pinturas necesarias
Tintas necessárias

Colori necessari
Använda färger

Tarvittavat värit
Du trenger følgende farger

Nødvendige farger
Необходимые краски

Potrzebne kolory
Απαιτούμενα χρώματα

Gerekli renkler
Potřebné barvy

Szükséges színek
Potrebne barve

A

anthrazit, matt 9
anthracite grey, matt
anthraciet, mat
antracita, mate
antracite, fosco
antracite, opaco
antracit, matt
antrasiti, himmeä
koksgrå, mat
antrasitt, matt
антрацит, матовый
antracyt, matowy
ανθρακί, ματ
antrasit, mat
antracit, matná
antracit, matt
tamno siva, matt

B

staubgrau, matt 77
dust grey, matt
gris poussière, mat
stolgrjs, mat
ceniciento, mate
cinzento de pó, fosco
grigio sabbia, opaco
dammgrå, matt
pölynharmaa, himmeä
stovgrå, mat
stovgrå, matt
серый пыльный, матовый
szary kurz, matowy
χρῶμα σκόνης, ματ
toz grisi, mat
prachově šedá, matná
porszürke, matt
prah siva, mat

C

aluminium, metallic 99
aluminium, metallic
aluminium, métallique
aluminium, metallic
aluminio, metalizado
aluminio, metálico
alluminio, metallico
aluminium, metallic
aluminium, metalliskt
aluminium, metallak
aluminium, metallic
алюминиевый, металлический
aluminium, metaliczny
ολουμινίου, μεταλλικό
aluminium, metalik
hliniková, metaliza
aluminium, metall
aluminium, metalik

D

lederbraun, matt 84
leather brown, matt
brun cuir, mat
lederbruin, mat
marrón cuero, mate
castanho couro, fosco
marrone cuoio, opaco
läderbrun, matt
nahkanuskea, himmeä
läderbrun, mat
läzbrun, matt
коричневая кожа, матовый
brunatny jak skóra, matowy
καφέ δέρματος, ματ
deri kahverengi, mat
koženě hnědá, matná
börbarna, matt
koža rjava, mat

E

panzergrau, matt 78
tank grey, matt
gris blindé, mat
pansergrjs, mat
plomioz, mate
cinzento militar, fosco
color carro armato, opaco
pansargrå, matt
panssarinharmaa, himmeä
kampvogngrå, mat
pansargrå, matt
серый танк, матовый
szary czolg., matowy
γκρι ταנקς, ματ
panzer grisi, mat
páncéřové šedá, matná
páncéřszürke, matt
oklopno siva, mat

F

helloliv, matt 45
light olive, matt
olive clair, mat
olijf-licht, mat
aceituna, mate
oliva claro, fosco
oliva chiaro, opaco
ljusoliv, matt
valsean oliivi, himmeä
lysoliv, mat
lys oliven, matt
светло-оливковый, матовый
jasnooliwk., matowy
ανοιχτό χακί, ματ
açik zeytuni, mat
světleolivová, matná
világos oliv, matt
svetlo oliva, mat

G

Schwarzgrün, matt 40
Black green, matt
Vert noir, mat
Zwartgroen, mat
Negro verdoso, mate
Verde-preto, mate
Nero verde, opaco
Svartgrön, matt
Mustanvihreä, matta
Sortgrön, mat
Sortgrön, matt
Черно-зеленый, матовый
Czarnozielony, matowy
Πρασινόχρῶμο, ματ
Siyah yeşil, mat
Feketeszöld, matt
Černozelená, matná
Črnazelena, brez leska

90 %

H

Hellblau, matt 49 +
Light blue, matt
Bleu clair, mat
Lichtblau, mat
Azul claro, mate
Azul-claro, mate
Blu chiaro, opaco
Ljusbå, matt
Vaaleansininen, matta
Lyseblå, mat
Lysblå, matt
Светло-синий, матовый
Jasnoniebieski, matowy
Μπλε ανοιχτό, ματ
Açik mavi, mat
Világoskék, matt
Svĕtle modrá, matná
Svetlomodra, brez leska

10 %

weiß, matt 5
white, matt
blanc, mat
wit, mat
blanco, mate
branco, fosco
bianco, opaco
vit, matt
valkoinen, himmeä
hvid, mat
hvit, matt
белый, матовый
biały, matowy
λευκό, ματ
beyaz, mat
bilá, matná
fehér, matt
bela, mat

90 %

I

blaugrau, matt 79 +
greyish blue, matt
gris-bleu, mat
blauwgrjs, mat
gris azulado, mate
cinzento azulado, fosco
grigio blu, opaco
blågrå, matt
siniharmaa, himmeä
blågrå, mat
blågrå, matt
сине-серый, матовый
sivý, matowy
γκριζομπλέ, ματ
mavi gri, mat
modrošedá, matná
kékesszürke, matt
plavo siva, mat

10 %

weiß, matt 5
white, matt
blanc, mat
wit, mat
blanco, mate
branco, fosco
bianco, opaco
vit, matt
valkoinen, himmeä
hvid, mat
hvit, matt
белый, матовый
biały, matowy
λευκό, ματ
beyaz, mat
bilá, matná
fehér, matt
bela, mat

J

karmirod, matt 36
carmin red, matt
rouge carmin, mat
karmijnrood, mat
carmin, mate
vermelho carmin, fosco
rosso carminio, opaco
karmirod, matt
karmiiniinpunainen, himmeä
karmirod, mat
karmirod, matt
красный кармин, матовый
karmirovy, matowy
κόκκινο όδιήθῶ, ματ
lái rengi, mat
krbově červená, matná
kárminpiros, matt
šminka rdeča, mat

K

laubgrün, seidenmatt 364
leaf green, silky-matt
vert feuille, satiné mat
bladgroen, zijdemat
verde follaje, mate seda
verde gaio, fosco sedoso
verde foglia, opaco seta
lövgroen, sidenmatt
lehdenvihreä, silkkihimmeä
løvgrön, silkematt
løvgrön, silkematt
лиственно-зеленый, шелк.-матовый
zielony liściasty, jedwabisto-matowy
πράσινο φυλλωμάτων, μεταξ, ματ
yaprak yeşili, ipek mat
zelená jako listí, hedvábně matná
lombzöld, selyemmatt
list zelena, svila mat

L

gelb, matt 15
yellow, matt
jaune, mat
geel, mat
amarillo, mate
amarelo, fosco
giallo, opaco
gul, matt
keltainen, himmeä
gul, mat
gul, matt
желтый, матовый
žółty, matowy
κίτρινο, ματ
sari, mat
žlutá, matná
sárga, matt
rumena, mat

M

hellgrau, seidenmatt 371
light grey, silky-matt
gris clair, satiné mat
lichtgrjs, zijdemat
gris claro, mate seda
cinzento claro, fosco sedoso
grigio chiaro, opaco seta
ljusgrå, sidenmatt
vaaleanharmaa, silkkihimmeä
lysegrå, silkematt
lysgrå, silkematt
светло-серый, шелковисто-матовый
jasnoszary, jedwabisto-matowy
ανοιχτό γκρι, μεταξωτό ματ
açik gri, ipek mat
světlešedá, hedvábně matná
világosszürke, selyemmatt
svetlo siva, svila mat

N

weiß, matt 5
white, matt
blanc, mat
wit, mat
blanco, mate
branco, fosco
bianco, opaco
vit, matt
valkoinen, himmeä
hvid, mat
hvit, matt
белый, матовый
biały, matowy
λευκό, ματ
beyaz, mat
bilá, matná
fehér, matt
bela, mat



zur besseren Ausbalancierung mit einem Gewicht beschweren

Add weight for improved stability

Pour une mise en place correcte alourdir

Voor evenwicht gewicht aanbrengen

Colocar un peso para obtener un mejor equilibrio

Utilizar um peso para melhor balanceamento

Per un migliore bilanciamento metterci su un peso

belasta med en vikt för bättre balansering

paremman tasapainon saavuttamiseksi kuormita painolla

Til bedre afbalancering vedhænges en vægt

For bedre avbalansering - belast med en vekt

для лучшего отбалансирования положить груз

dla lepszego wyrównowazenia obciężć ciężarkiem

για την καλύτερη αντιστάθμιση τοποθετείστε ένα βάρος

Daha iyi dengelemek için bir ağırlık koyun

Za úcelem lepsiho vyvázení zatížít závažím

a jobb kiegyenlítés érdekében egy nehezéssel ellátni

Zaradi boljše ravnoteže postaviti kontratežo z tegom

Nicht enthalten

Not included

Non fourni

Behoort niet tot de levering

No incluido

Non compresi

Não incluído

Ikke medsendt

Ingår ej

Ikke inkludert

Eivät sisälly

Δεν ονπεριλαμβάνεται

He содержит

Nem tartalmazza

Nie zawiera

Ni vsebovano

Içerisinde bulunmamaktadır

Neni obsaženo

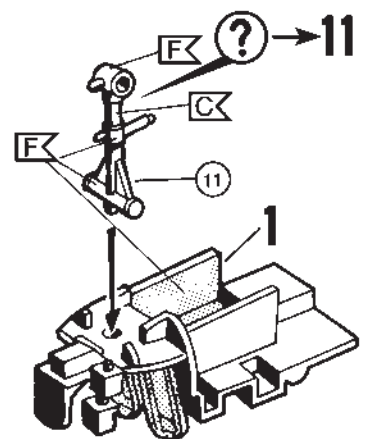
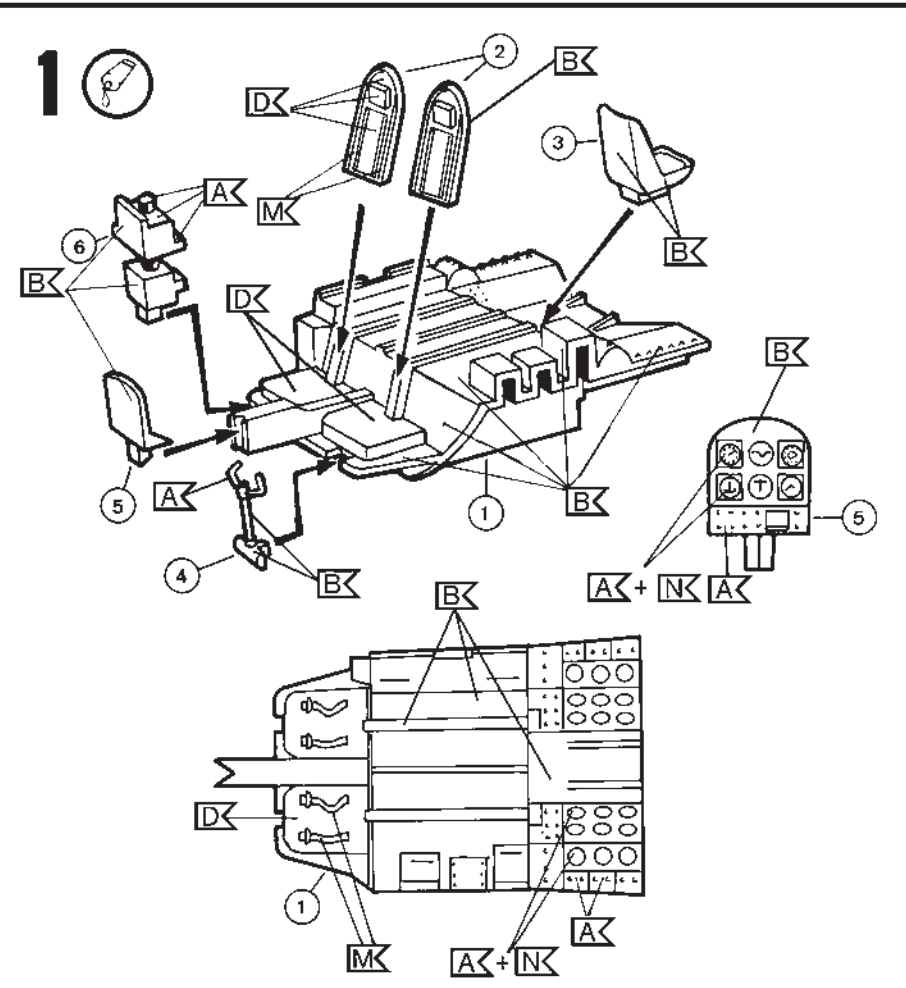
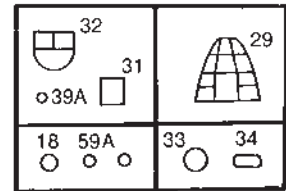
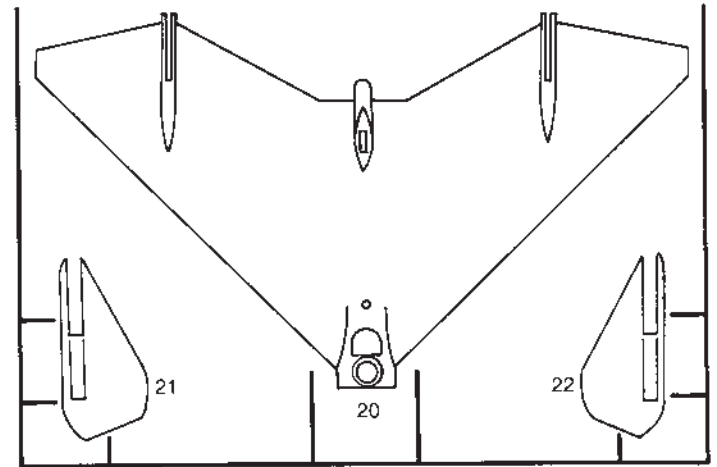
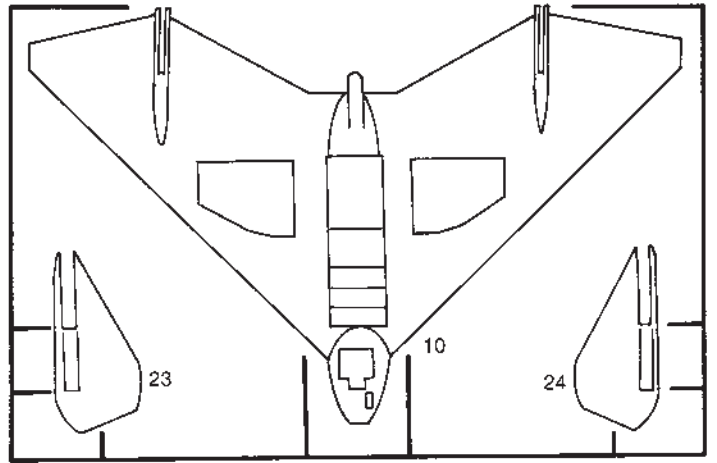
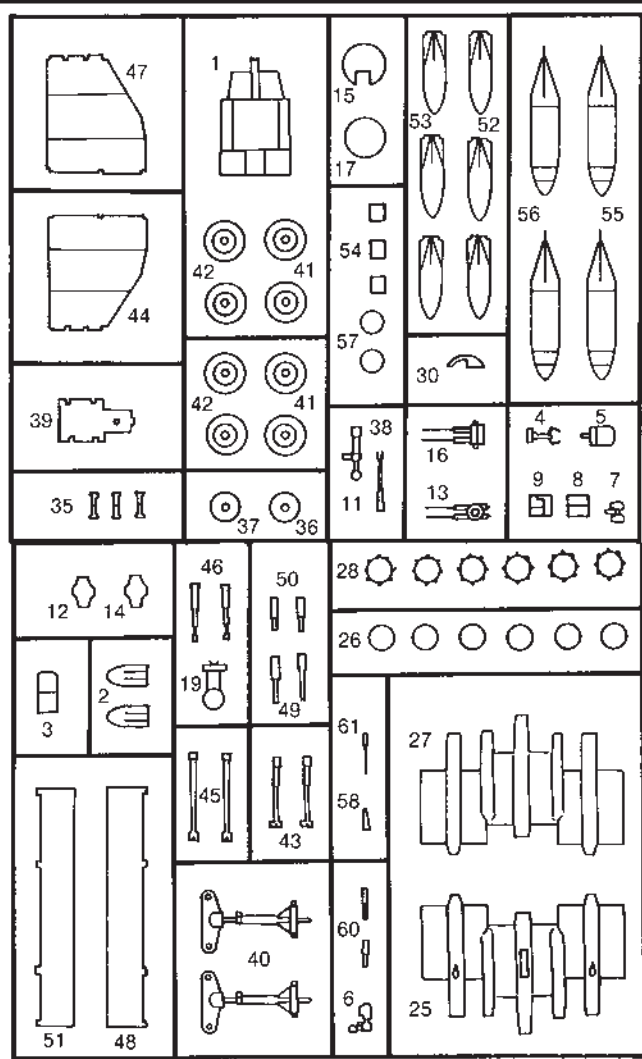

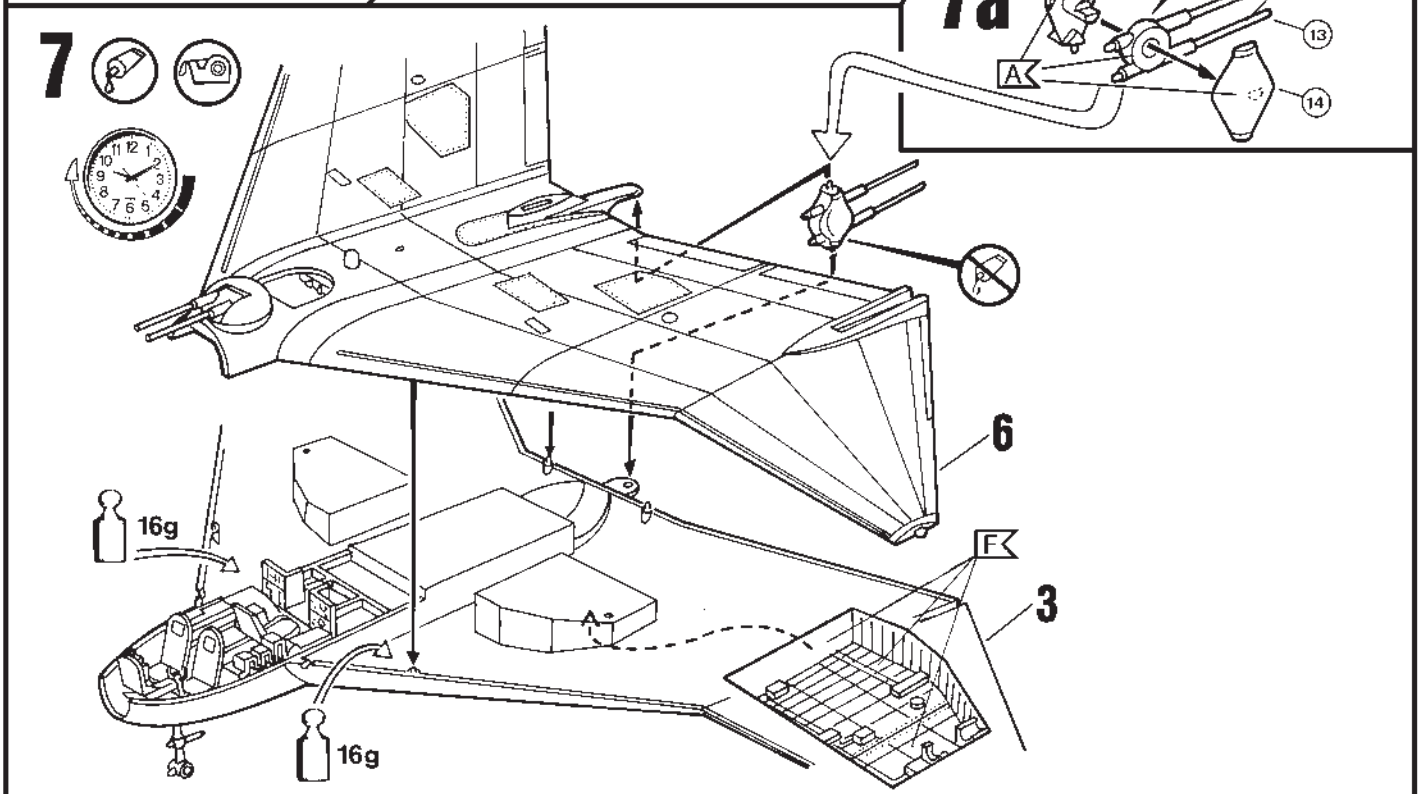
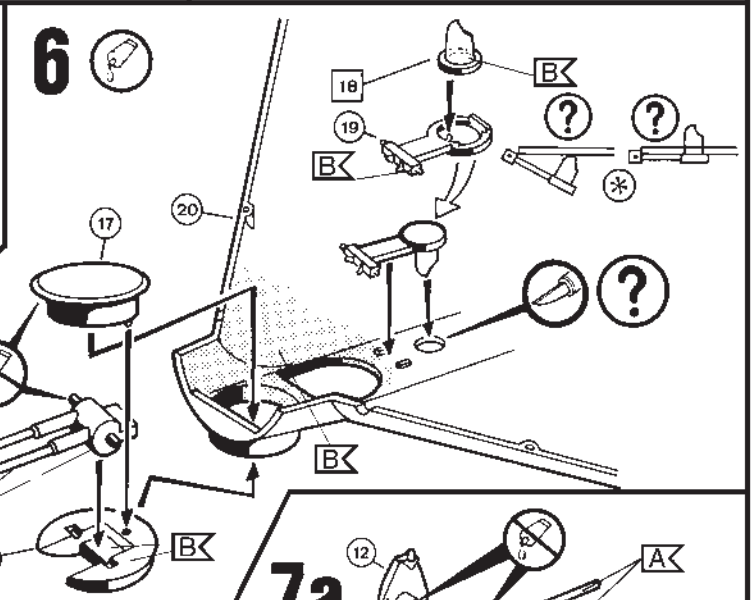
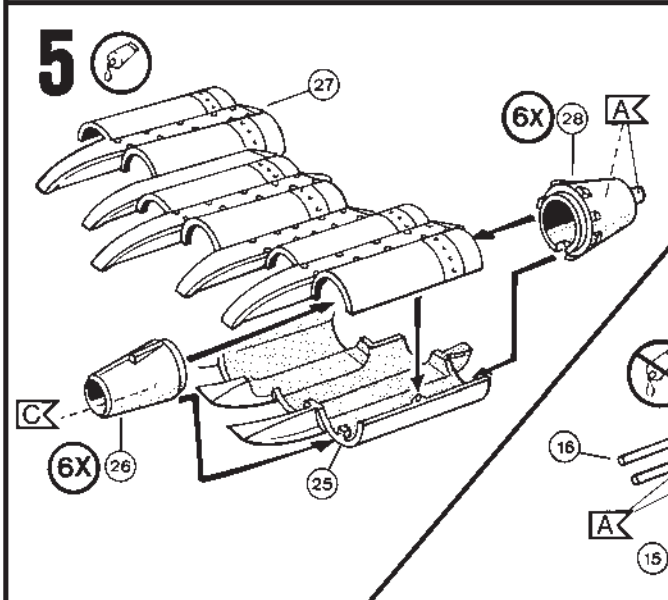
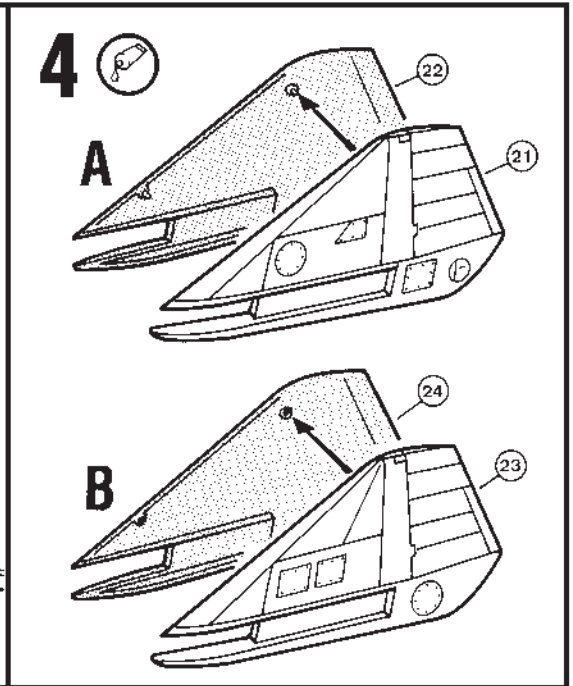
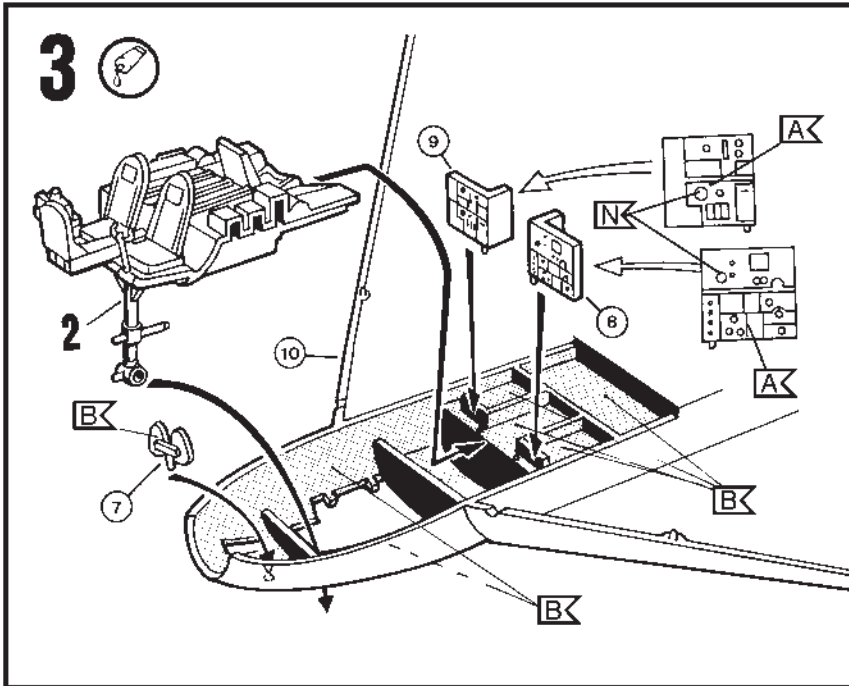

8

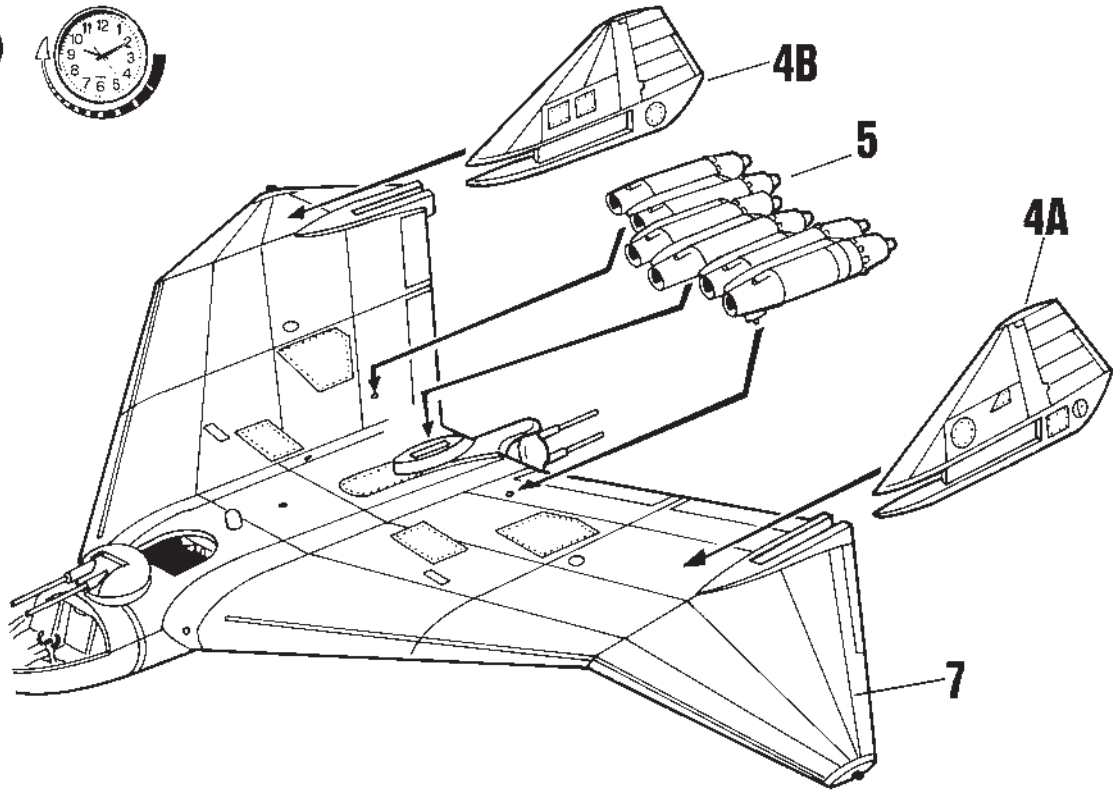

9

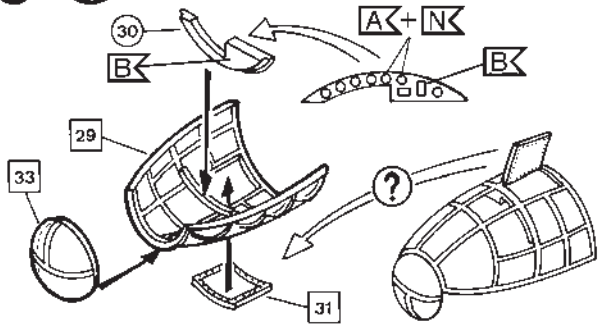

10

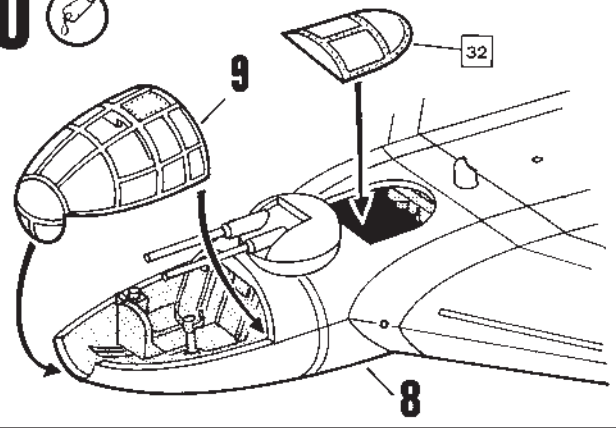

11

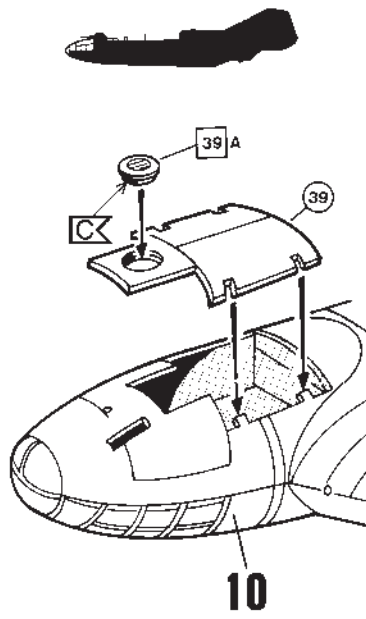

12

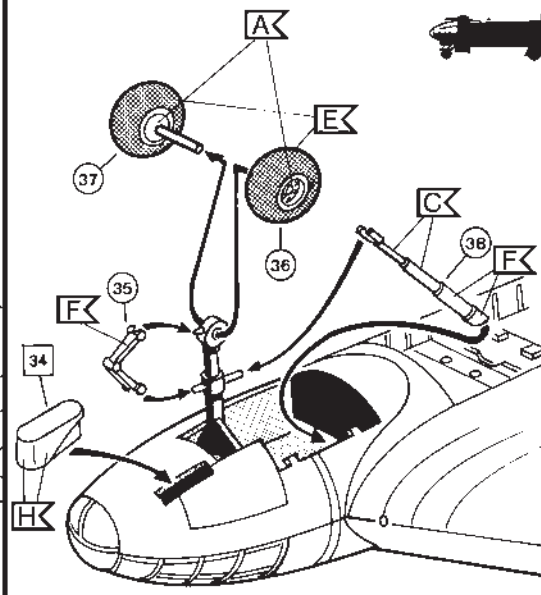

13

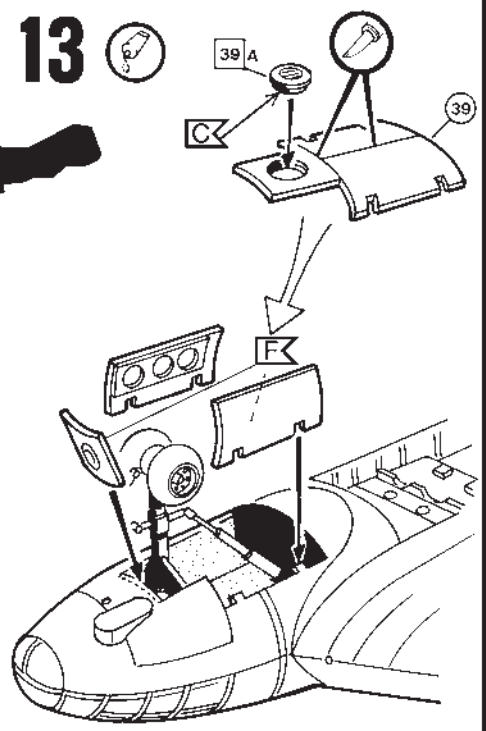

14



left

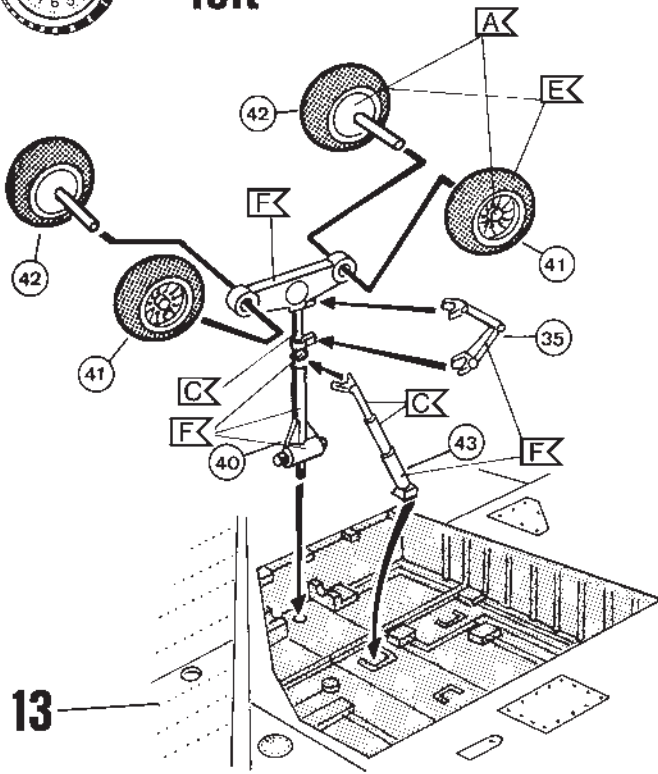

15



left

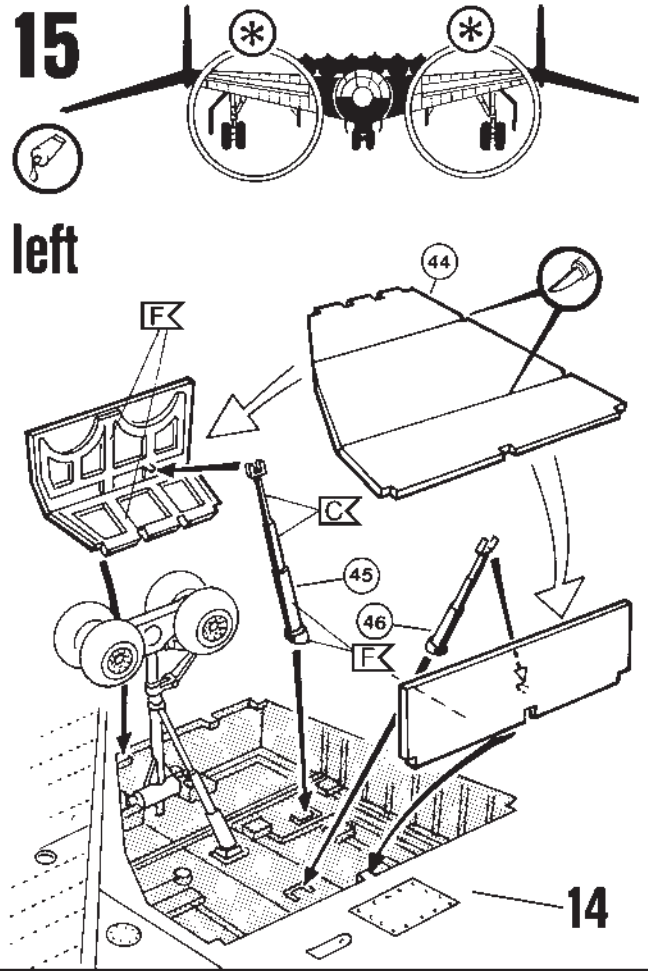

16



right

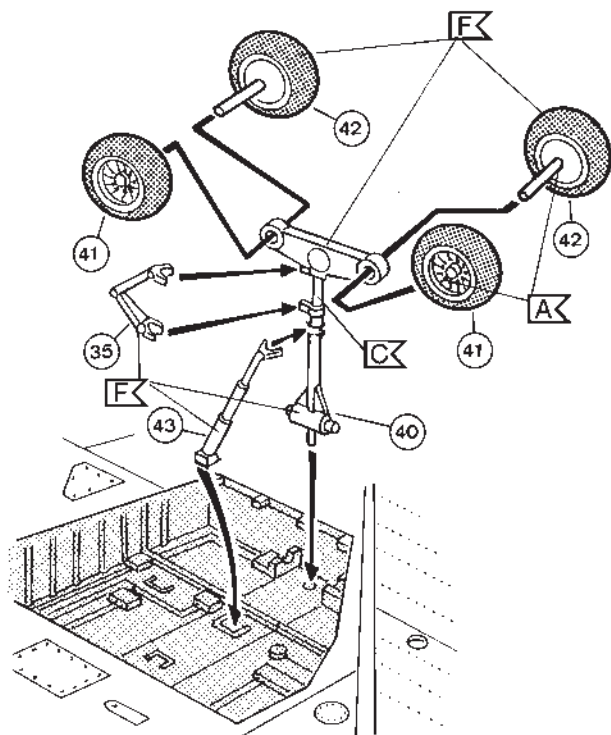

17



right

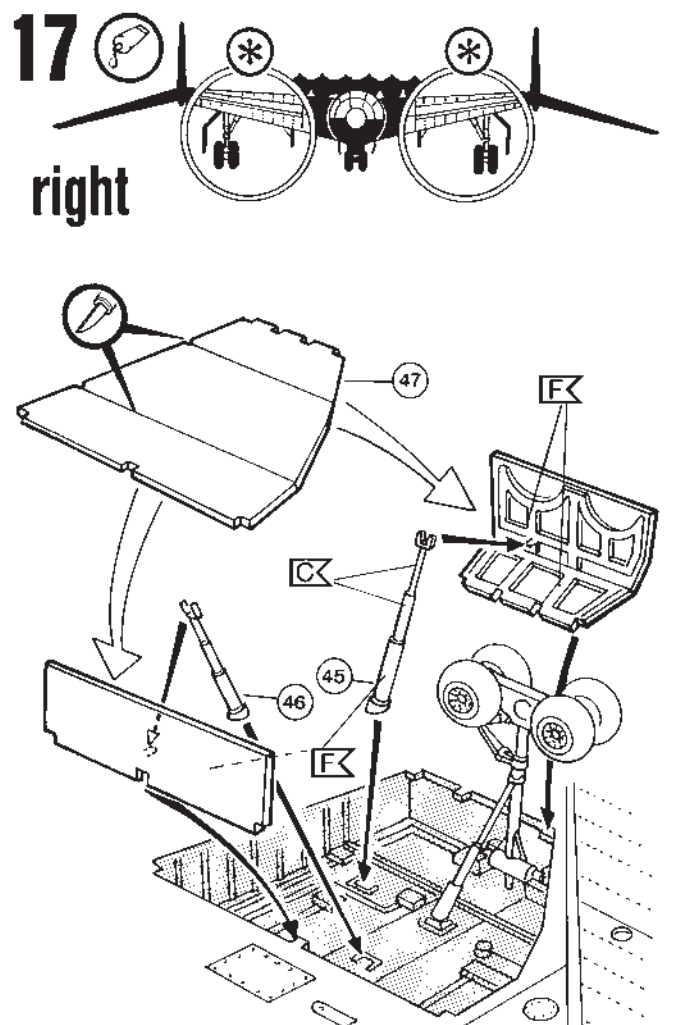

18  

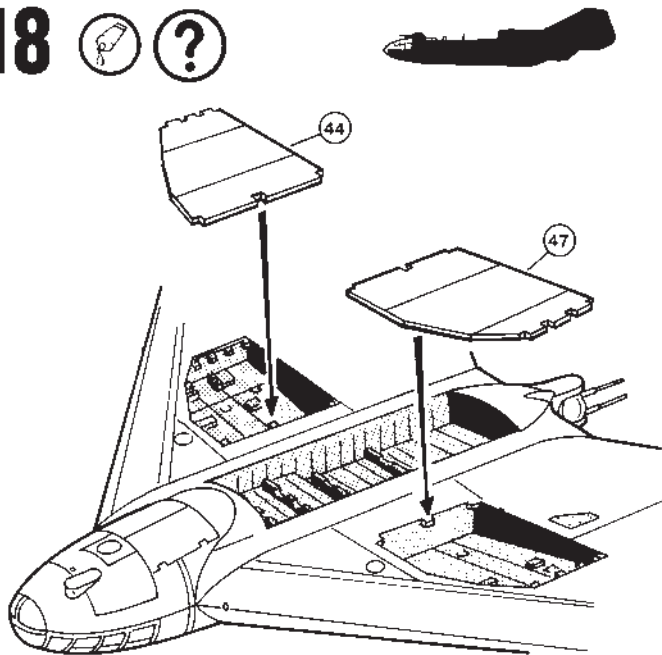

19  

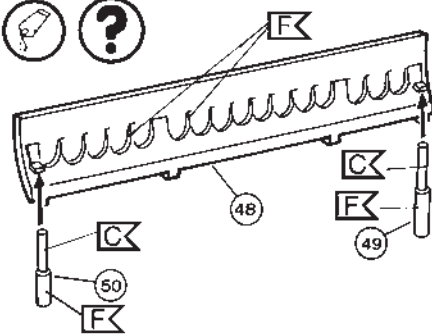

20

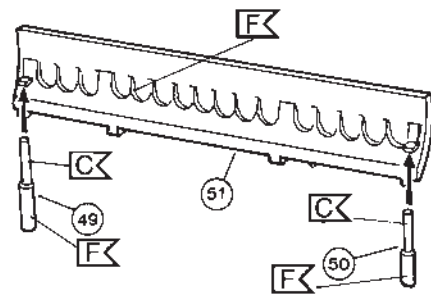

21  

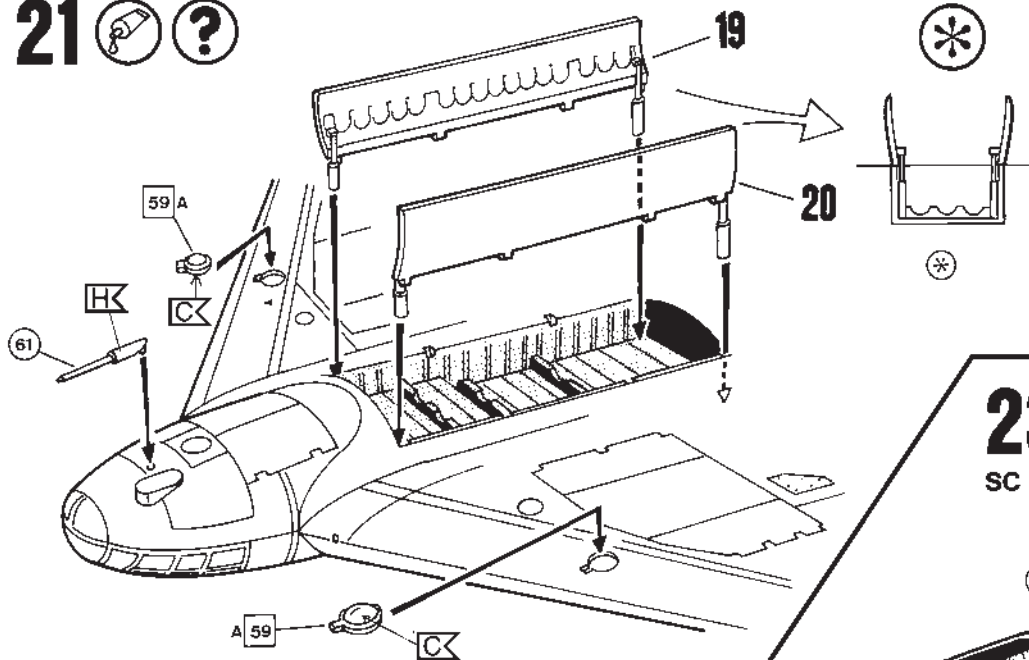

23



SC 1000 bomb

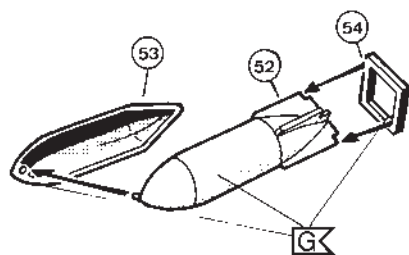

22  

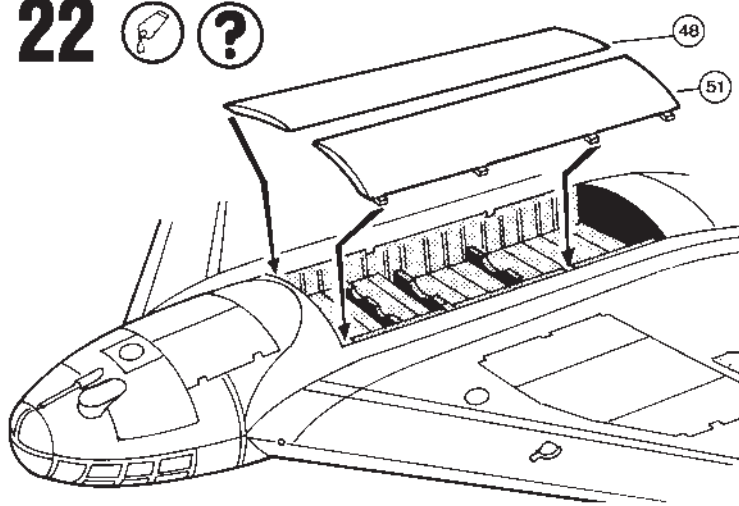

24



SC 2000 bomb

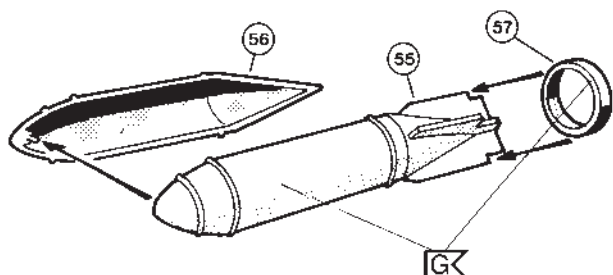

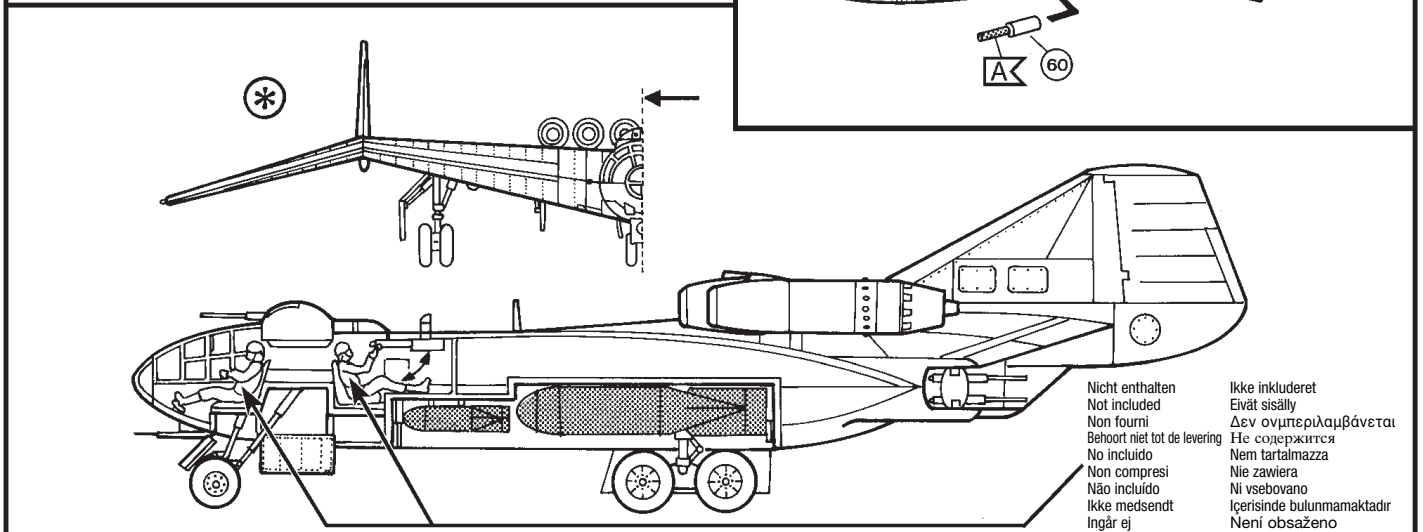
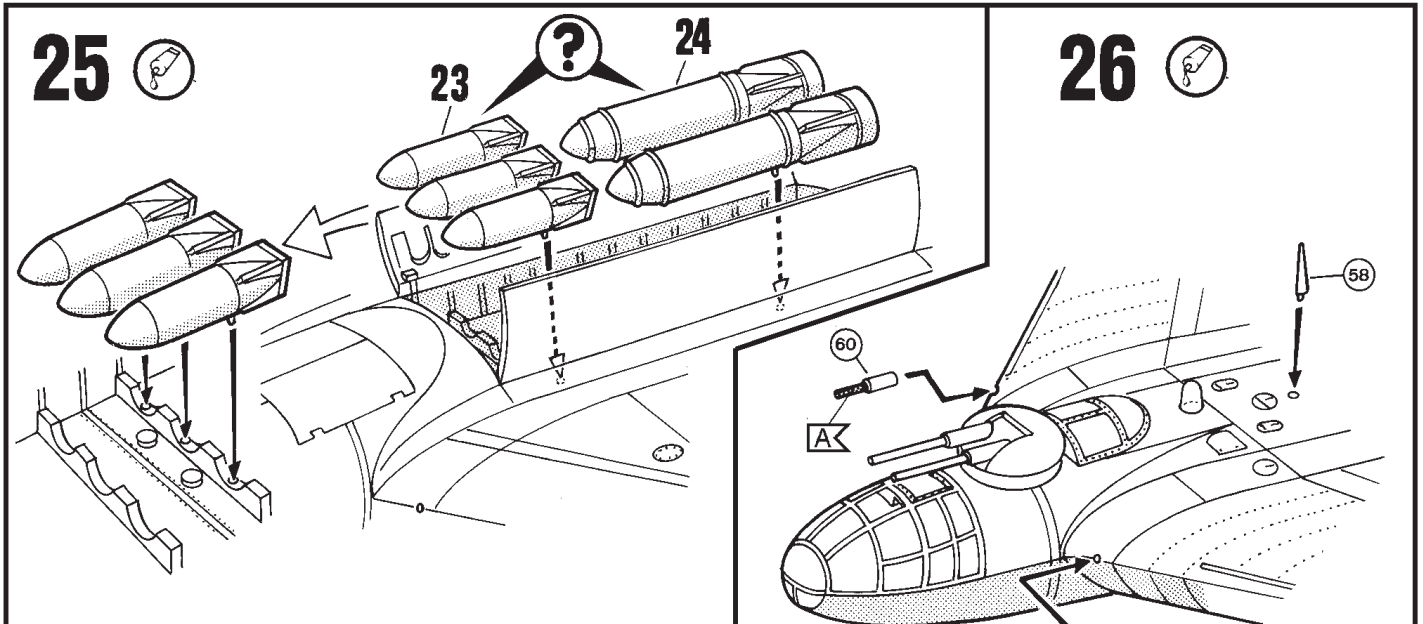

Nicht enthalten
 Not included
 Non fourni
 Behoort niet tot de levering
 No included
 Non compresi
 Não incluido
 Ikke medsendt
 Ingår ej

Ikke inkluderet
 Eivät sisälly
 Δεν συμπεριλαμβάνεται
 Не содержится
 Nem tartalmazza
 Nie zawiera
 Ni vsebovano
 İçerisinde bulunmamaktadır
 Není obsaženo

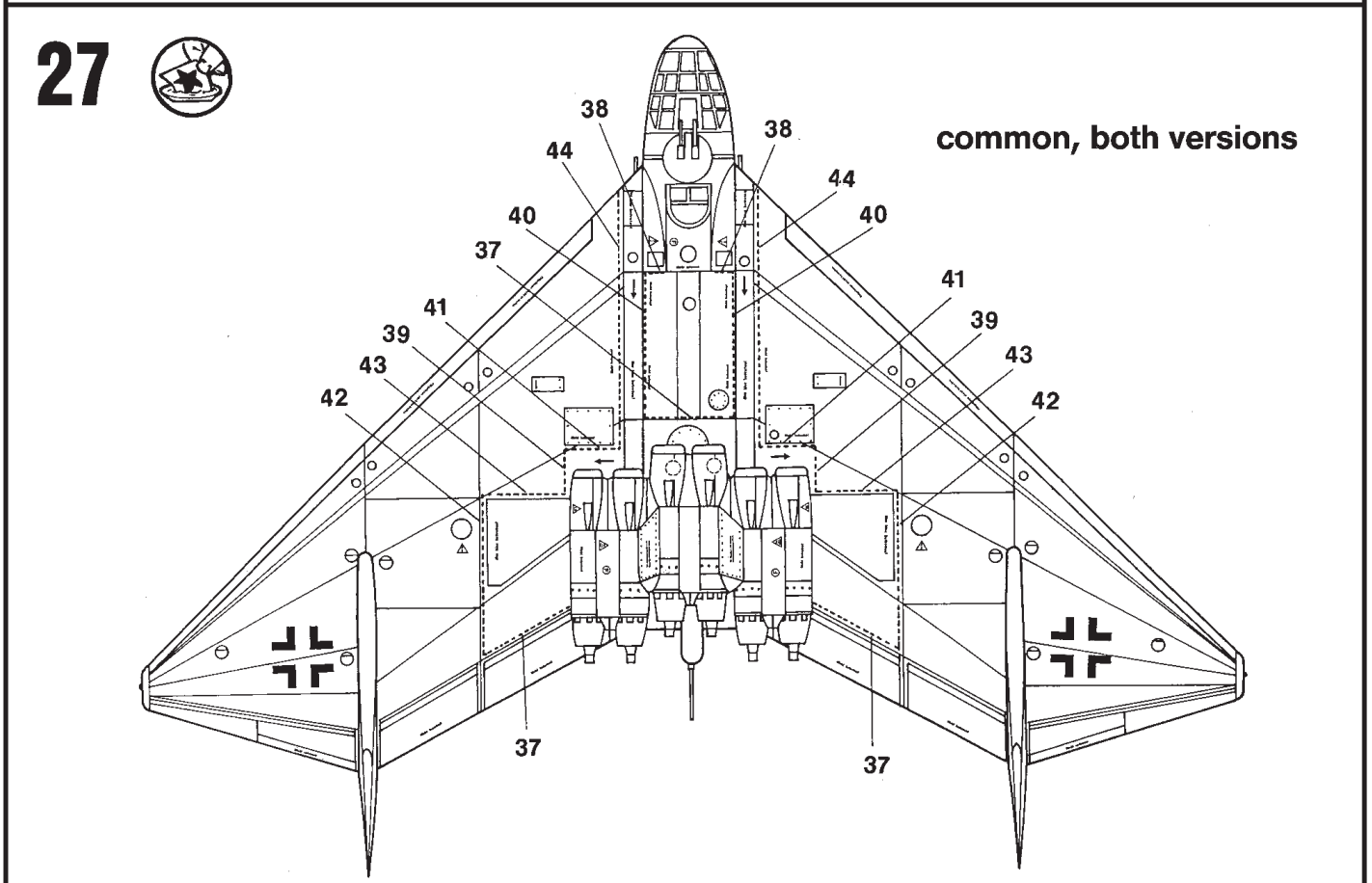

28



Arado Ar (E) 555 I/KG 100 Luftwaffe 1948 project

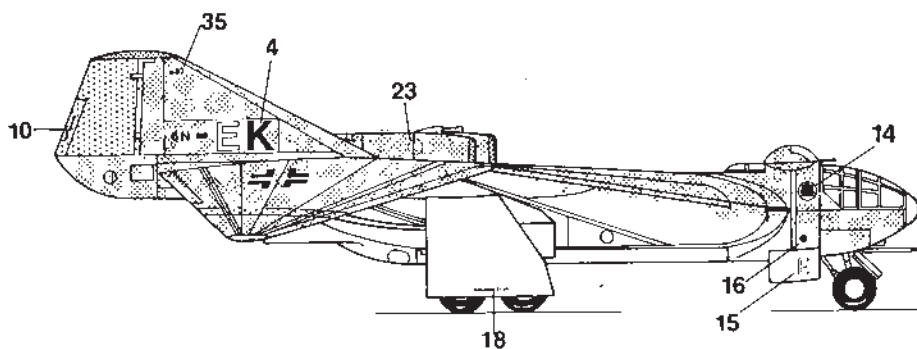
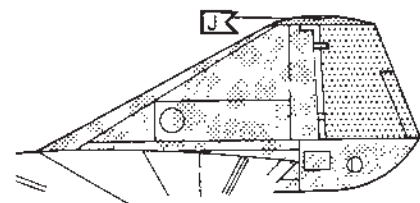
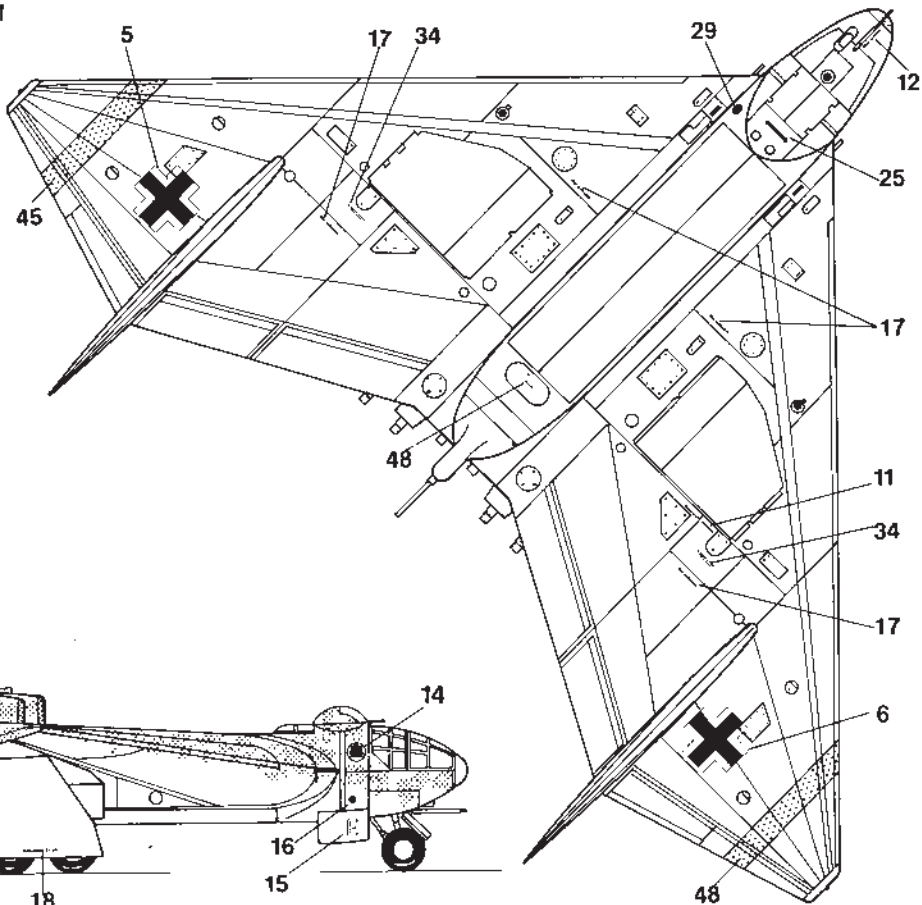
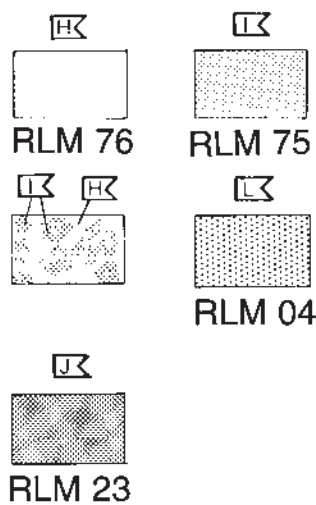
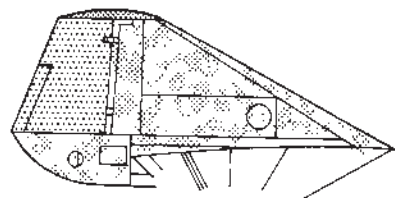
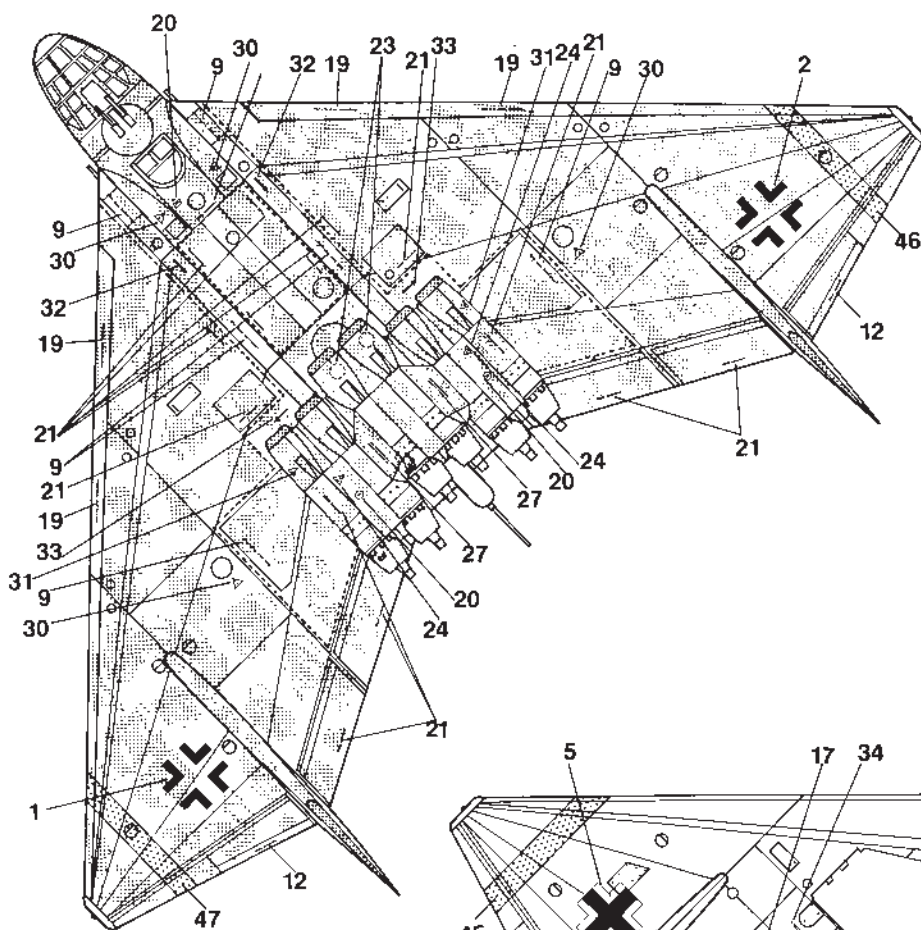
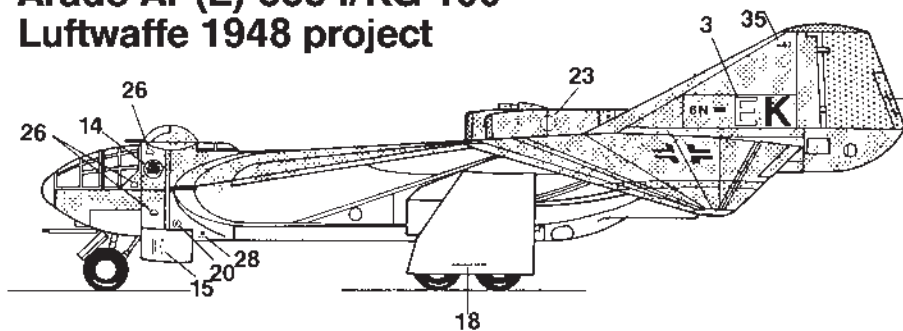

29



Luftwaffe, 1948 project wing/KG 200

