



Dassault Breguet ATLANTIC 1 „MFG3 Anniversary“

Als Ersatz für die veraltete Lockheed Neptun suchte die NATO 1958 in einer Ausschreibung nach einem geeigneten Nachfolger. Unter den 24 Projekten die von neun Ländern eingereicht wurden erhielt schließlich Breguet mit der Br1150 Atlantic den Zuschlag. Ein Grund für diese Entscheidung war auch die Tatsache das Breguet seinen Entwurf mit Rolls-Royce Tyne-Triebwerken ausgestattet hatte, die auch bei der zum gleichen Zeitpunkt angedachten Transall Verwendung finden sollten. An dem für den Bau der Atlantic verantwortlichen Konsortium waren neben Frankreich auch noch Deutschland, Holland, Belgien und Italien beteiligt. Nach dem Erstflug am 21. Oktober 1961 dauerte es weitere vier Jahre ehe die ersten Maschinen im Dezember 1965 an Frankreich und Deutschland ausgeliefert werden konnten. Die französische Aeronavale rüstete mit ihren 40 Maschinen die Flottilles No. 21F, 22F und 24F aus. Eine dieser Maschinen von der 24F, die als erste Einheit mit Atlantic ausgerüstet wurde, erinnerte 2005 mit besonderen Markierungen an dieses Ereignis. Sie kann aus dem REVELL-Bausatz gebaut werden. In Deutschland wurde die Atlantic beim Marineflieger-Geschwader 3 (MFG 3) in Nordholz eingesetzt. Der Dutch Marine Luchtvaartdienst ersetzte die Lockheed Neptun der 321.Squadron (auch diese Version ist im Bausatz enthalten) durch den Atlantik. Als letzte NATO-Einheit erhielt die 41. Stormo der italienischen Marine mit ihrer 87. und 88. Gruppo insgesamt 18 Maschinen. Nach 87 gebauten Maschinen wurde die Produktion der Atlantic 1974 eingestellt. Ähnlich wie bei der Transall ergab sich jedoch wenige Jahre später in Frankreich ein erneuter Bedarf. Mit zahlreichen Überarbeitungen und einer neuen Elektronik ging die Atlantic 2 1988 in Serie. Gebaut wurden bis 1997 weitere 28 Maschinen. Die Atlantic 2 kann neben dem im Waffenschacht untergebrachten Torpedos, Minen und Wasserbomben auch Exocet-Raketen zur Schiffsbekämpfung an Stationen unter der Tragfläche mitführen. Die Atlantic der ersten Serie wurden im Laufe ihrer Einsatzzeit ebenfalls ständig verbessert, so erhielten die Maschinen des MFG 3 statt der früher üblichen Tragflächen-Randbögen zusätzliche Behälter an der Tragflächenspitze. Außerdem wurde auf der Unterseite des hinteren Rumpfteils eine Abwurfanlage für Sonarbojen sowie ein zusätzlicher Radome eingebaut. Im Zuge der internationalen Verpflichtungen werden seit einigen Jahren auch Einheiten der Marineflieger mit Sea King und Atlantic am Horn von Afrika zur Überwachung der Schiffswege eingesetzt. Diese Atlantic tragen zum Teil große Markierungen an den Seitenleitwerken. Vier dieser Maschinen mit drei unterschiedlichen Zeichen können aus dem REVELL-Bausatz gebaut werden. Zu den Feiern „50 Jahre Bundeswehr“ die 2006 stattfinden wurde beim MFG 3 auch eine Atlantic mit einem außergewöhnlichen Sonderanstrich in den deutschen Farben versehen. Auch diese Maschine kann aus dem REVELL-Bausatz gebaut werden. Nach der In-Dienst-Stellung der Orion wurden einige ältere Atlantic aus dem Dienst genommen und an deutsche Museen abgegeben.

Technische Daten:

Einsatzzweck	Langstrecken-Seeaufklärung und U-Bootbekämpfung
Spannweite	36.30 m
Spannweite mit Flügelpods	37.42 m
Länge	31.75 m
Höhe	11.33 m
Triebwerke	SNECMA (Rolls-Royce) Tyne RTy. 20 Mk. 21
Leistung	6 195 WPS
Leergewicht	24 000 kg
Startgewicht max	43 500 kg.
Höchstgeschwindigkeit	658 km/h
Reisegeschwindigkeit für max. Reichweite	320 km/h
Anfangssteigleistung	12,44 m /sec
Dienstgipfelhöhe	10 500 m
Flugdauer max	18 Stunden
Reichweite max. (mit Reserve)	7 970 km
Bewaffnung	4 x Zielsuch-Torpedos oder 9 Akustik-Torpedos sowie See-Minen und Wasserbomben
Besatzung	10 - 12 Mann

Dassault Breguet ATLANTIC 1 „MFG3 Anniversary“

In 1958 NATO invited tenders for a suitable replacement for the ageing Lockheed Neptune. Final out of twenty-four tenders from nine countries, Breguet with their Br1150 Atlantic were awarded the contract. One of the grounds for this decision was the use of Rolls Royce Tyne engines in the Breguet design as these engines were also planned for use in the Transall. Apart from France the design consortium also included members from Germany, Holland, Belgium and Italy. It took another four years after the maiden flight on 21 October 1961 before the first production aircraft were delivered to France and Germany in December 1965. The French Aeronavale, equipped Flotilla's No 21F, 22F and 24F with its forty aircraft. One of these aircraft from Flotilla 24F, the first to be equipped with the new Atlantic carried a special livery in 2005 to mark the occasion. A model of this aircraft can be constructed from the REVELL Kit. In Germany the Atlantic was deployed with Marineflieger-Geschwader 3 (MFG) – Naval Air Squadron No3 – based in Nordholz. The Dutch Marine Luchtvaartdienst replaced the Lockheed Neptune's of No321 Squadron with the new Atlantic, this model can also be constructed from the REVELL Kit. The Italian Navy's Gruppo 87 and 88 of the 41st Stormo were the last NATO Units to receive the Atlantic with a total of eighteen aircraft. Production of the Atlantic ended in 1974 after 87 aircraft had been built. In similar circumstances to the Transall however, France found a further requirement for more Atlantic's a couple of years later. The Atlantic 2 went into production in 1988 with many modifications and a new electronic fit. A further 28 aircraft were built up until 1997. Apart from weapons carried in the fuselage weapons bay such as torpedo's, mines and depth charges Exocet anti-ship missiles were also carried on under-wing pylons. Atlantic's from the first production series were continuously modified during their career. Aircraft of the German MFG3 received extra pods on the wing-tips instead of the old round tip. A Sonar-Buoy dispenser and extra Radome were also attached below the rear fuselage. In accordance with international commitments Naval Units equipped with Sea King and Atlantic aircraft have been deployed to patrol the shipping lanes around the Horn of Africa for some years. Some of these aircraft carry large markings on their fins. Four of these aircraft with three different markings can be constructed from the REVELL Kit. An Atlantic belonging to MFG3 was given a very special livery containing the colours of the German Flag to mark the "50 Years Bundeswehr" celebrations in 2006. This aircraft can also be constructed from the REVELL Kit. Some older Atlantic's were de-commissioned after the introduction to service of the ORION and given to German Museum's.

Technical Data.

Role:	Long-range Maritime Reconnaissance and Anti-submarine warfare.
Wingspan:	36.30 m
Wingspan with tip pods:	37.42 m
Length:	31.75 m
Height:	11.33 m
Engines:	SNECMA (Rolls-Royce) Tyne RTy20 Mk.21
Power:	6195 WPS
Empty Weight:	24 000 kg
Maximum Take-off Weight:	43 500 kg.
Maximum Speed:	658 km/h
Cruising Speed for	
Maximum Range:	320 km/h
Initial Rate of Climb	12,44 m /sec
Service Ceiling:	10500 m
Maximum Fight Time	18 Hours
Maximum Range incl. Reserves	7970 km
Armament:	4 x Target Acquisition Torpedo's or 9 x Acoustic Torpedo's plus Mines und Depth Charges
Crew:	10 - 12 Persons

Vor dem Zusammensetzen gut durchlesen!

Read before you start!

D: Achtung: Jedes Teil ist nummeriert (1). Reihenfolge der Montageschritte beachten. Benötigte Werkzeuge: Messer und Feile zum Entfernen und Entgraten der Teile (2) Gummiband, Klebeband und Wäscheklammern zum Zusammenhalten der geklebten Einzelteile (3). Plastikteile in einer milden Waschlösung reinigen und an der Luft trocknen, damit der Farbanstrich und die Abziehbilder besser haften. Vor dem Ankleben prüfen ob Teile passen, Klebstoff sparsam auftragen Chrom und Farbe an den Klebeflächen entfernen. Kleine Teile anstreichen, bevor sie vom Rahmen entfernt werden (4) (5). Farben gut durchtrocknen lassen, erst dann den Zusammenbau fortsetzen. Jedes Abziehbildmotiv einzeln ausschneiden und ca. 20 Sekunden in warmes Wasser tauchen. Das Motiv an der bezeichneten Stelle vom Papier abschieben und mit Löschpapier andrücken.

NL: OPGELET: Voor de montage eerst goed de handleiding lezen. Elk onderdeel is genummerd (1). Let op de montagevolgorde. Benodigd gereedschap: mes en vijl voor het afbramen van de onderdelen (2); elastiek, plakband en wasknijpers voor het bij elkaar houden van de gelijmde onderdelen (3). Plastic onderdelen met een zacht afwasmiddel reinigen en vanzelf laten drogen, zodat de verf en de decals beter hechten. Controleer voor het lijmen of de onderdelen passen; lijm dun opbrengen. Chrom en verf van de lijmvlakken verwijderen. Kleine onderdelen vervaardigd van het raam worden verwijderd (4) (5). Verf goed laten drogen, dan pas verdergaan met de montage. Elke decal afzonderlijk uitsnijden en ca. 20 sec. in warm water dopen. De decal op de aangegeven plaats van het papier schuiven en met vloeipapier aandrukken.

GB: ATTENTION: Read the instructions thoroughly prior to assembly. Each component is numbered (1). Adhere to specified sequence of assembly. Tools required: knife and file for removal of components from frame (2); rubber band, adhesive tape and clothes pegs for clamping components together after applying adhesive (3). Clean plastic components in a mild detergent solution and allow to air-dry so that paint and transfers adhere better. Prior to applying adhesive, check to see whether the components fit together; apply adhesive sparingly. Remove chrome and paint from the contact surfaces. Paint small components before removing them from the frame (4) (5). Allow paint to dry well, and only then continue to assemble. Cut out each transfer individually and immerse in warm water for approx. 20 seconds. Slide transfer off paper and into designated position, then press on with blotting paper.

F: ATTENTION: lisez bien la notice de montage avant de commencer. Chaque pièce est numérotée (1). Respectez l'ordre des opérations. Outils nécessaires : couteau et lime pour ébarber les pièces (2); élastiques, ruban adhésif et pinces à linge pour maintenir les pièces collées (3). Nettoyez les pièces en matière plastique dans une solution douce de produit de lavage et faites-les sécher à l'air afin que la peinture et les décalcomanies tiennent mieux. Avant de mettre la colle, vérifiez si les pièces s'adaptent bien les unes aux autres; mettez peu de colle. Enlevez le chrome et la peinture des surfaces de collage. Peignez les petites pièces avant de les détacher de la grappe (4) (5). Laissez bien sécher la peinture avant de poursuivre l'assemblage. Découpez chaque décalcomanie séparément et plongez-la dans de l'eau chaude pendant 20 secondes environ. À l'endroit marqué, faites glisser le motif pour le séparer du papier et pressez-le sur remplacement avec du papier buvard.

E: ¡ATENCIÓN! Antes de comenzar con el ensamblaje, leer detenidamente las instrucciones. Cada pieza va numerada (1). Téngase en cuenta el orden de operaciones del ensamblaje. Herramientas necesarias: Cuchilla y lima para desbarbar las piezas (2). Cintas de goma, cinta adhesiva y pinzas de ropa para sujetar las piezas pegadas (3). Lavar las piezas de plástico en una solución de detergente suave y dejar que se sequen al aire para mejorar así la adhesión de la pintura y de las calcomanías. Antes de aplicar el pegamento comprobar si las piezas quedan correctamente adaptadas. Aplicar el pegamento sin excederse. Alejar de las superficies de pegado el cromado y la pintura. Pintar las piezas pequeñas antes de desprenderlas de su sujeción (4) (5). Antes de proseguir con el ensamblaje, dejar que se seque bien la pintura. Recortar las calcomanías una por una y sumergirlas durante unos 20 segundos en agua caliente. Deslizar del papel la calcomanía en el lugar adecuado y apretarla colocando encima de ella papel secante.

I: ATTENZIONE: Prima dell'assemblaggio leggere attentamente le istruzioni di montaggio. Ogni pezzo è numerato (1). Tener presente la successione delle fasi di assemblaggio. Attrezzi necessari: coltello e lima per togliere la sbavatura dai pezzi (2), nastro adesivo e mollette da bucato per tenere insieme i pezzi singoli dopo averli incollati (3). Lavare i particolari in plastica con un detergente delicato e lasciarli asciugare all'aria, per una migliore adesione dello strato di colore e della figura decalabile. Prima di incollare, verificare che i pezzi si abbino bene tra di loro; applicare il collante con parsimonia. Togliere cromo e colore dalle superfici da incollare. Dipingere i piccoli accessori sul supporto prima di rimuoverli (4) (5). Far seccare bene la vernice prima di proseguire con l'assemblaggio. Ritagliare singolarmente ogni figura ed immergerla in acqua tiepida per 20 secondi circa. Applicare il motivo nella posizione segnata e tamponarlo con carta assorbente.

S: OBS: Läs instruktionerna noga igenom innan du sätter modellen samman. Vardera detalj är nummerad (1). V g bryta till den i sammansättningsstegen. Verktyg, som du kommer att behöva : kniv och fil för att skrapa detaljerna rena (2), gummiringar, tejp och klädnyper för att hålla samman de limmade detaljerna (3). Rengör plastdetaljerna in en mild tvättmedel-lösning och torka dem i luften för att lack och dekaler skall hålla bättre. Kolla, om detaljerna passar ihop innan du klisar dem och använd limmet sparsamt. Avlägsna krom och lack från ytor, som kommer att limmas ihop. Mål de små detaljerna innan du avlägsnar dem från ramen (4) (5). Låt lacket riktigt torka igenom innan du fortsätter med sammansättningen. Skär av varje dekalmotiv enskilt och doppa det i varmt vatten i ca 20 sekunder. Flytta motivet bort från pappret genom att trycka vid det angivna stället och tryck fast med löskpapper.

DK: BEMÆRK: Inden sammensætningen begynder, skal byggevejledningen læses godt igennem. Hver del er nummereret (1). Rækkefølgen af monteringsstrinene skal overholdes. Nødvendigt værktøj: Kniv og fil til afgratning af delene (2), gummibånd, tape og tøjklammer til at holde de klistrede (3) enkeltdele sammen. Plastikdelene renses i en mild sæbeudløsning og lufttørres så malingen og overføringsbillederne bedre kan hæfte. Inden påførelsen kontrolleres om delene passer; limen påføres sparsommeligt. Krom og farve fjernes fra klæbefladerne. De små dele males inden de fjernes fra rammen (4) (5). Lad farven tørre godt inden sammensætningen fortsættes. Overføringsbilledernes motiver skæres ud enkeltvis og dyppes ca. 20 sek. i varmt vand. Skub motivet fra papiret og tryk det fast med trækpapper.

GR: ΠΡΟΣΟΧΗ: Πριν τη συναρμολόγηση, διαβάστε καλά τις οδηγίες. Κάθε εξάρτημα είναι αριθμημένο (1). Προσέξτε τη σειρά "των βημάτων" συναρμολόγησης. Απαιτούμενα εργαλεία: μαχαίρι και λίμα για τη λείανση των εξαρτημάτων (2), λαστιχένια ταινία, κολλητική ταινία και μανταλάκια για τη συγκράτηση των κολλημένων μεμονωμένων εξαρτημάτων (3). Καθαρίστε τα πλαστικά εξαρτήματα μέσα σε ένα "μαλακό" καθαριστικό διάλυμα και στεγνώστε τα στον αέρα, ώστε να υπάρξει καλύτερη πρόσφυση του χρώματος και των χαλκομανιών. Πριν το κόλλημα, ελέγξτε αν ταιριάζουν μεταξύ τους τα εξαρτήματα. Επαλείψτε οικονομικά την κόλλα. Απομακρύνετε από τις επιφάνειες επικάλυψης, χρώμο και βαφή. Βάψτε τα μικρά εξαρτήματα, πριν απομακρυνθούν από το πλαίσιο (4) (5). Αφήστε να στεγνώσουν καλά τα χρώματα και ύστερα συνεχίστε τη συναρμολόγηση. Κόψτε ξεχωριστά το κάθε μοτίβο των χαλκομανιών και βουτήξτε το σε ζεστό νερό για περί. 20 δευτερόλεπτα. Απομακρύνετε το μοτίβο από το χαρτί, στο σηματοδομένο σημείο και πιέστε το με το στυπώχαρτο.

N: OBS! Les nøye igjennom monteringsanvisningen før sammenbyggingen. Hver del er nummerert (1). Folg rekkefølgen på monteringsstrinene. Nødvendig værktøy: Kniv og fil for fjerning av grader på delene (2), gummibånd, tape og klesklyper for å holde sammen de limede enkeltdelene (3). Rengjør plastdelene i mildt såpevann og la dem lufttørke, slik at fargen og bildene sitter bedre. Før pålimingen må det kontrolleres om delene passer: Ta på litt lim. Fjern krom og farge på klæbeflatene. Mal de små delene før de fjernes fra rammen (4) (5). La fargene tørke godt før sammenbyggingen fortsettes. Skjær ut hvert av motivene for seg og legg dem i varmt vann i ca. 20 sekunder. Skyv motivet fra papiret på det merkede stedet og trykk på med trækpapper.

P: ATENÇÃO: Antes de iniciar a montagem leia atentamente o manual de construção. Todas as partes componentes são numeradas (1). Atentar para a sequência das etapas de montagem. Ferramentas necessárias: Faca e lixa para aparar a reborda das peças (2), elástico, fita adesiva e molas de roupa para sustentar as peças (3) durante a colagem. As peças de matéria plástica devem ser limpas numa solução fraca de detergente e secas ao ar, de forma que a demão de tinta e os decalques tenham uma boa adesão. Antes de colar, verificar se as peças encaixam; utilizar a cola em pequena quantidade. Eliminar o cromado e a tinta das superfícies a serem coladas. Não passar cola nas peças que ainda se encontram fixas na grade de matéria plástica. Pintar as peças pequenas antes de retirá-las da grade (4) (5). Deixar a tinta secar completamente para depois continuar com a montagem. Cortar separadamente cada um dos decalques e mergulhá-los em água morna durante aproximadamente 20 segundos. Decalcar os motivos do papel na posição indicada e secar com mata-borrão.

FIN: HUOMIO: Lue rakennusohjeet huolellisesti ennen kokoamista. Jokainen osa on numeroitu (1). Huomioi osien oikea asennusjärjestys. Tarvittavat työkalut: Veitsi ja viila osien ylimääräisten pursettujen poistamiseen (2); kuminauha, teippiä ja pyykkipoikia yhteennilmitettujen osien paikkaamiseksi (3). Puhdista muoviosat miedolla pesuaineliuoksella ja anna niiden kuivua itsenäisin, jotta maali ja siirtokuvat tarttuvat niihin paremmin. Tarkasta ennen liimausta, että osat sopivat toisiinsa; levitä liimaa säästeliäästi. Poista kromaus ja maali liimainnosta. Maalaa pienet osat ennen kuin irrotat ne pidinraameista (4) (5). Anna maalin kuivua kunnolla ennen kuin jatkat kokoamista. Leikkaa jokainen siirtokuva erikseen irti ja upota lämpimään veteen n. 20 sekunniksi. Irrota kuvio paperiin merkityistä kohdasta samalla painamalla inuappaperi kuvion toista puolta vasten.

RUS: Внимание: Перед сборкой хорошо прочитать руководство по монтажу. Каждая деталь пронумерована (1). Соблюдать последовательность монтажа. Необходимые рабочие инструменты: нож и напильник для зачистки деталей (2); резиновая лента, клейкая лента и зажимы для сушки белья для прижимания склеиваемых отдельных деталей (3). Детали из пластика очистить в растворе мягкого моющего средства и высушить на воздухе для того, чтобы краска и переводные картинки лучше прилипали. Перед приклеиванием проверить, подходят ли детали; клей наносить экономно. Хром и краску удалить с поверхностей склеивания. Небольшие детали покрасить перед тем, как они будут удалены из рамок (4) (5). Краску необходимо хорошо просушить, только после этого продолжать сборку. Каждую соответствующую переводную картинку отдельно вырезать и примерно на 20 секунд окунуть в теплую воду. На обозначенном месте картинку отделить от бумаги и прижать промокательной бумагой.

PL: UWAGA: Przed składowaniem przeczytać dokładnie instrukcję montażu. Każda część jest ponumerowana (1). Zwrócić uwagę na kolejność przeprowadzania poszczególnych punktów montażowych. Potrzebne narzędzia: nóż oraz pilnik do usunięcia zadziorów z poszczególnych elementów (2); taśma gumowa, taśma klejająca, klamperki do bielizny dla przytrzymania sklejonych elementów (3). Wymyć plastikowe części w wodzie z delikatnym środkiem myjącym oraz osuszyć na powietrzu, aby zapewnić lepszą przylepność farby oraz kalkomanii. Sprawdzić przed przyklejeniem, czy dane elementy pasują do siebie; nanosić klej oszczędnie. Usunąć chrom oraz farbę z powierzchni przeznaczonych do klejenia. Małe elementy pomalować jeszcze przed wycięciem z ramki (4) (5). Farbę dobrze wysuszyć, dopiero potem kontynuować składanie części. Wyciąć pojedynczo każdy z motywów kalkomanii i zanurzyć na 20 sekund w ciepłej wodzie. Ściągnąć motyw z papieru na oznaczone miejsce i docisnąć bibułą.

TR: DİKKAT: Birleştirmeden önce montaj talimatını iyice okuyun. Her parça numaralandırılmıştır (1). Montaj adımıyla sırasıyla dikkat edin. Gereklî takımlar: Parçaların çapağını almak için bıçak ve eğe (2); lastik bant, yapıştırma bantları bir arada tutmak için yapıştırma bandı ve çamaşır mandalı (3). Plastik parçaları yumuşak bir deterjan ile temizleyin, boya ve çirkatmaların daha iyi yapışması için, açık havada kurutun. Yapıştırma önce parçaların uyup uymadığını kontrol edin; yapışkanı idareli bir şekilde sürün. Krom ve boyayı, yapıştırma yüzeylerinden temizleyin. İskeletten sökmeden önce, küçük parçaları boyayın (4) (5). Boyayı, ince kurumaya bırakın, sonra montaja devam edin. Her çirkatma motifini tek tek kesin ve yaklaşık 20 saniye sıcak suya daldırın. Motifli işaretlenen yere kağıttan itin ve silme kağıdı ile bastırın.

CZ: POZOR: Před sestavením montážního návodu důkladně pročíst. Každý díl je očíslován (1). Dbejte na pořadí montážních kroků. Potřebné nástroje: Nůž a pilník k odstranění výronků na dílech (2); pryžová páska, lepicí páska a količky na kuličky na předřizování lepených jednotlivých dílů (3). Díly z plastické hmoty vyčistit v roztoku jemného pracího prostředku a nechat vyschnout na vzduchu, za účelem zajištění lepší přilnavosti barevného nátěru a obtisků. Před nalepením zkontrolovat, zdali díly lepicí lepidlo nanášet úsporně. Chrómu a barvu na lepených plochách odstranit. Malé díly natřít před jejich odstraněním z rámu (4) (5). Barvy nechat dobře proschnout, teprve potom pokračovat v sestavení. Každý motiv obtisků jednotlivě vyřiznout a ponořit do teplé vody na dobu přibližně 20 sekund. Motiv na označeném místě z papíru odsunout a přitlačit pomocí stíračího papíru.

H: FIGYELM: Az összeállítás előtt az építési útmutatót alaposan át kell olvasni. Minden alkatrészt számmal láttak el (1). A szerelési lépések sorrendjére ügyelni kell. Szükséges szerszámok: kés és reszelő az alkatrészek sorjatlánításához (2); gumiszalag, ragasztószalag és ruhacsipesz az összeragasztott alkatrészek megtartásához (3). A műanyag alkatrészeket lágy mosószeres oldatban kell tisztítani és a levegőn kell megszáritani, hogy a festékbevonat és a matricák jobban tapadjanak. A felragasztás előtt ellenőrizni kell, hogy az alkatrészek összeillenek-e; a ragasztóanyagot takarékosan kell felhordani. A kromot és festéket a ragasztási felületekről el kell távolítani. A kisméretű alkatrészeket a keretből történő eltávolítás előtt be kell festeni (4) (5). A festékeket hagyni kell jól megszáradni, az összeszerelést csak ezután szabad folytatni. Minden matricá-motívumot egyenként kell kivágni és kb. 20 másodpercere meleg vízbe kell áztatni. A motívumot a megjelölt helyen a papírról lecsúsztatni és itatóspapírral felnyomni.

SLO: UPOZORILO: pred sestavo dobro prečitati upozorilo za sestavo. Vsaki del je označen (1). Slediti sled postopka pri montiranju. Potrebno orodje: noži in orodje za delitev delov (2), gumijaste trake, traka z lepilom in klučke za učvrstilo zalepenih delov (3). Plastične dele očistiti z blagim deterdžentom, sižiti na zraku da bi se sloji barve in preslikači boljše prijeli. Pre lepljenje obvetno preveriti če se deli uklopajo eden v drugi. Počasi nanašati lepilo. Na površinah na katere nanašamo lepilo treba prvo odstraniti hrom in barvo. Manjše dele prvo treba premazati in pšotem oddeliti z rama (4) (5). Pustiti da se barve dobro posušijo, in šele potem nastaviti z sestavljanjem. Vsaki preslikač posebno zrezati in potopiti v toplo vodo ca. 20 sekund. Motiv na odrejenem mestu oddeliti od papirja in nanesti z upijačem.

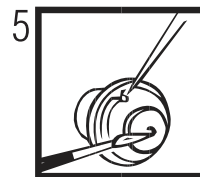
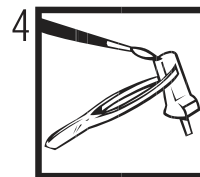
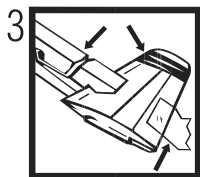
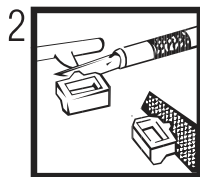
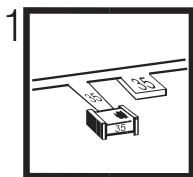

Verwendete Symbole / Used Symbols

Bitte beachten Sie folgende Symbole, die in den nachfolgenden Baustufen verwendet werden.

Veuillez noter les symboles indiqués ci-dessous, qui sont utilisés dans les étapes suivantes du montage.

Sivånse tener en cuenta los símbolos facilitados a continuación, a utilizar en las siguientes fases de construcción.

Si prega di fare attenzione ai seguenti simboli che vengono usati nei successivi stadi di costruzione.

Huomoini seuraavat symbolit, joita käytetään seuraavissa kokoonsovituksissa.

Legg merke til symbolene som benyttes i monteringsstoppene som følger.

Prosze zwracać na następujące symbole, które są użyte w poniższych etapach montażowych.

Daha sonraki montaj basamaklarında kullanılabacak olan, aşağıdaki sembollere lütfen dikkat edin.

Kérjük, hogy a következő szimbólumokat, melyek az alábbi építési fokokban alkalmazásra kerülnek, vegyék figyelembe.

Please note the following symbols, which are used in the following construction stages.

Neem a.u.b. de volgende symbolen in acht, die in de onderstaande bouwfasen worden gebruikt.

Por favor, preste atenção aos símbolos que seguem pois os mesmos serão usados nas próximas etapas de montagem.

Observer: Nedanstående piktogram används i de följande arbetsmomenten.

Lag venligst merke til følgende symboler, som benyttes i de følgende byggestadier.

Παρακαλώ, observeτε κεντρικά τα ακόλουθα σύμβολα, τα οποία χρησιμοποιούνται στις παρακάτω βελβίδες συναρμολόγησης.

Dbejte prosím na dále uvedené symboly, které se používají v následujících konstrukčních stupních.

Prosimo za Vašu pozornost na sledeće simbole ki se uporabljajo v naslednjih korakih gradbe.



Abziehbild in Wasser einweichen und anbringen
Soak and apply decals
Mouiller et appliquer les décalcomanies
Transfer in water even laten weken en aanbrengen
Remojat y aplicar las calcomanías
Pôr de molho em água e aplicar o decalque
Immergere in acqua ed applicare decalcomanie
Blôt og fást dekalerna
Kostuta siirtokuvaa vedessä ja aseta paikalleen
Fukt motivet i varmt vann og før det over på modellen
Dypp bildet i vann og sett det på
Переводя изображение в воду и нанести
Zmęczyć kalkomanie w wodzie a następnie nakleić
Βουτήξτε τη χαλκομανία στο νερό και τοποθετήστε τη
Çikartmayı suda yumuşatın ve koyun
Óbítsk namočit ve vodě a umistit
a matricát vizben beázatni és felhelyezni
Preslikáť potopiti v vodo in zatem nanašati



Kleben
Glue
Coller
Lijmen
Engomar
Colar
Incollare
Limmas
Limmas
Limmaa
Limes
Lim
Клеить
Клеить
Nie przyklejać
μη κολλάει
Yapıştırma
Lepeni
ragasztani
Lepiti



Nicht kleben
Don't glue
Ne pas coller
Niet lijmen
No engomar
Não colar
Non incollare
Limmas ej
Älä limmaa
Skal IKKE limes
Ikke lim
Не клеить
Не клеить
Nie przyklejać
μη κολλάει
Yapıştırma
Lepeni
nem szabad ragasztani
Ne lepi



Wahlweise
Optional
Facultatif
Naar keuze
No engomar
Alternado
Facultativo
Valfritt
Valitsoehtoisesti
Valgfritt
Valgfritt
На выбор
Do wyboru
εναλλακτικά
Seçmeli
Voliteľne
tetszés szerint
način izbire



Anzahl der Arbeitsgänge
Number of working steps
Nombre d'étapes de travail
Het aantal bouwstappen
Número de operaciones de trabajo
Número de etapas de trabalho
Número di passaggi
Antal arbetsmoment
Työvaiheiden lukumäärä
Antall arbeidstrinn
Antall arbeidstrinn
Количество операций
Liczba operacji
αριθμός των εργασιών
İş safhalarının sayısı
Počet pracovních operací
a munkafolyamatok száma
Številkva koraka montaže



Klebeband
Adhesive tape
Dévidoir de ruban adhésif
Plakband
Cinta adhesiva
Fita adesiva
Nastro adesivo
Tejp
Teippi
Tape
Tape
Клейкая лента
Taşma klejca
κόλλητική ταινία
Yapıştırma bandı
Lepici páska
ragasztószalag
Traka za leplim



Klarsichtteile
Clear parts
Pièces transparentes
Transparente onderdelen
Limpiar las piezas
Peça transparente
Parte transparente
Genomsiktliga detaljer
Läpínákyvát osat
Glassklare deler
Gjennomsiktige deler
Προзрачные детали
Elementy przezroczyste
διαφανή εξαρτήματα
Şeffaf parçalar
Průzračné díly
átátszó alkatrészek
Delki ki se jasno vide



Gleichen Vorgang auf der gegenüberliegenden Seite wiederholen
Repeat same procedure on opposite side
Opérer de la même façon sur l'autre face
Dezelfde handeling herhalen aan de tegenoverliggende kant
Realizar el mismo procedimiento en el lado opuesto
Repertir o mesmo procedimento utilizado no lado oposto
Stessa procedura sul lato opposto
Upprepa proceduren på motsatta sidan
Toista sama toimenpide kuten viereisellä sivulla
Det samme arbejdet gentages på den modsatliggende side
Gjenta prosedyren på siden tværs overfor
Повторять такую же операцию на противоположной стороне
Taki sam przebieg czynności powtórzyc na stronie przeciwnej
επανάλξτε την ίδια διαδικασία στην απέναντι πλευρά
Aynı işlemi karşı tarafta tekrarlayın
Stejny postup zopakovat na protilehlé straně
ugyanazt a folyamatot a szemben található oldalal megismételni
Isti postopek ponoviti in na suprotni strani



Abbildung zusammengesetzter Teile
Illustration of assembled parts
Figure représentant les pièces assemblées
Afbeelding van samengevoegde onderdelen
Ilustración piezas ensambladas
Figura representando peças encaixadas
Illustrazione delle parti assemblate
Bilden visar dalarna hopsatta
Kuva yhteenselitystä osista
Illustrasjonon viser de sammensatte delene
Illustrasjon, sammensatte deler
Изображение смонтированных деталей
Rysunek złożonych części
απεικόνιση των συναρμολογημένων εξαρτημάτων
Birleştirilen parçaların şekli
Zobrazení sestavených dílů
összeállított alkatrészek ábrája
Slika slopljenega dela



Mit einem Messer abhaken
Detach with knife
Détacher au couteau
Met een mesje afhakken
Separar con un cuchillo
Separar uma das partes da peça
Separare con coltello
Skär loss med kniv
Intra valsa
Aðskmes med en kniv
Skjær av med en kniv
Отрезать ножом
Ođdelić nožem
αποχρίστε με ένα μαχαίρι
Bir bıçak ile kesin
Oddelit pomocí nože
kés segítségével leválasztani
Oddeliti z nožem



Loch bohren
Make a hole
Faire un trou
Maak een gat
Practicar un taladro
Perfurar
Fare un foro
Borra hål
Pora reikä
Der bores et hul
Bor hull
Προσверлить отверстие
wywiercić otwór
ανοίξτε τρύπα
Delik açın
Vyvrat díru
lyukat fúrni
Narediti lukinjo



Entfernen
Remove
Détacher
Verwijderen
Sacar
Retirar
Eliminare
Tag loss
Poista
Fjern
Удалить
Usunąć
απομακρύνετε
Temizleyin
Odstranit
eltávolítani
Ostraniti



Bauteile trocknen lassen
Allow the parts to dry
Laisser sécher les pièces
Onderdelen laten drogen
Dejar secar las piezas
Deixar secar os componentes
Far asciugarsi i componenti
Anna osien kuivua
La delene tørke
Lad komponenterne tørre
Låt byggdelarna torka
Дать деталям высохнуть
Części pozostawić do wyschnięcia
Αφήστε τα μέρη να στεγνώσουν
Yarı parçaların kurumaya bırakınız
Alkatrészeket hagyja száradni
Jednotlivé díly nechte zaschnout
Pustite da sestavni deli posušijo



Schwarzen Faden benutzen
Use black thread
Employer le fil noir
Gebruik zwarte draad
Utilizar hilo color negro
Utilizar fio preto
Usare filo nero
Använd svart tråd
Käytä mustaa lankaa
Benyt en sort
Bruk svart
Использовать черные нитки
Użyć czarny nici
χρησιμοποιείτε την καφέ μαύρου
Kahverengi siyah iplik kullanın
Použit černé vlákno
barna fekete fonalat kell használni
Uporabljati črni nit



Nicht einschließen
Do not include
Nicht einschließen
Behoort niet tot de levering
No incluido
Non compresi
Não incluído
Ikke medsendt
Ingår ej
Ikke inkluderet
Eivät sisälly
Δεν συμπεριλαμβάνεται
He содержится
Nem tartalmazza
Nie zawiera
Ni vsebovano
Içerisinde bulunmamaktadır
Není obsaženo



zur besseren Ausbalancierung mit einem Gewicht beschweren
Add weight for improved stability
Pour une mise en place correcte allourdir
Voor evenwicht gewicht aanbrengen
Colocar un peso para obtener un mejor equilibrio
Utilizar un peso para melhor balanceamento
Per un migliore bilanciamento metterci su un peso
belasta med en vikt för bättre balansering
paremman tasapainon saavuttamiseksi kuormita painolla
Til bedre afbalancering vedhænges en vægt
For bedre afbalansering - belast med en vekt
для лучшего отбалансирования положить груз
dla lepszego wyównowazenia obciążyć ciężarkiem
για την καλύτερη αντιστάθμιση τοποθετήστε ένα βάρος
Daha iyi dengelemek için bir ağırlık koyun
Za účelem lepšího vyvážení zatížit závažím
a jobb kiegyenlítés érdekében egy nehézkkel ellátni
Zaradi boljše ravnotežet postaviti kontrtežo z tegom

Nicht enthalten
Not included
Non fourni
Behoort niet tot de levering
No incluido
Non compresi
Não incluído
Ikke medsendt
Ingår ej
Ikke inkluderet
Eivät sisälly
Δεν συμπεριλαμβάνεται
He содержится
Nem tartalmazza
Nie zawiera
Ni vsebovano
Içerisinde bulunmamaktadır
Není obsaženo

Beiliegenden Sicherheitstext beachten / Please note the enclosed safety advice

D: Beiliegenden Sicherheitstext beachten und nachschlagebereit halten.

E: Please note the enclosed safety advice and keep safe for later reference.

F: Respecter les consignes de sécurité ci-jointes et les conserver à portée de main.

NL: Houdt u aan de bijgaande veiligheidsinstructies en hou deze steeds bij de hand.

E: Observar y siempre tener a disposición este texto de seguridad adjunto.

I. Seguire le avvertenze di sicurezza allegate e tenerle a portata di mano.

P: Ter em atenção o texto de segurança anexo e guardá-lo para consulta.

S: Beakta bifogad säkerhetstext och håll den i beredskap.

FIN: Huomioi ja säilytä ohjeiset varoitukset.

DK: Overhold vedlagte sikkerhedsanvisninger og hav dem liggende i nærheden.

N: Ha alltid vedlagt sikkerhetstekst klar til bruk.

RUS: Соблюдать прилагаемый текст по технике безопасности, хранить его в легко доступном месте.

PL: Stosować się do załączonej karty bezpieczeństwa i mieć ją stale do wglądu.

GR: Προσέξτε τις συνημμένες υποδείξεις ασφάλειας και φυλάξτε τις έτσι ώστε να τις έχετε πάντα σε διαθέσιμη οα.

TR: Ekteki güvenlik talimatlarını dikkate alıp, bakabileceğiniz bir şekilde muafaza ediniz.

CZ: Dbejte na přiložený bezpečnostní text a mějte jej připravený na dosah.

H: A mellékelt biztonsági szöveget vegye figyelembe és tartsa fellapozásra készen!

SLO: Priložena varnostna navodila izvajajte in jih hranite na vsem dostopnem mestu.

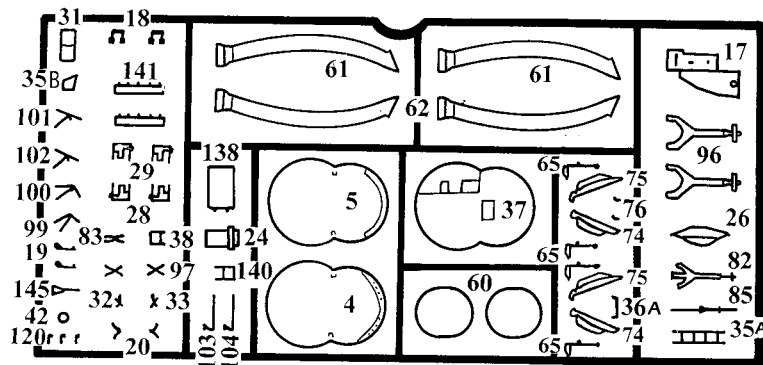
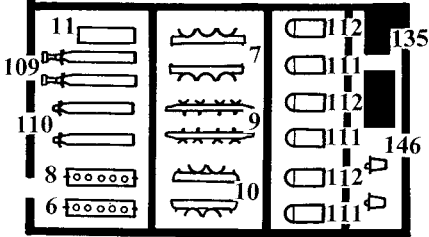
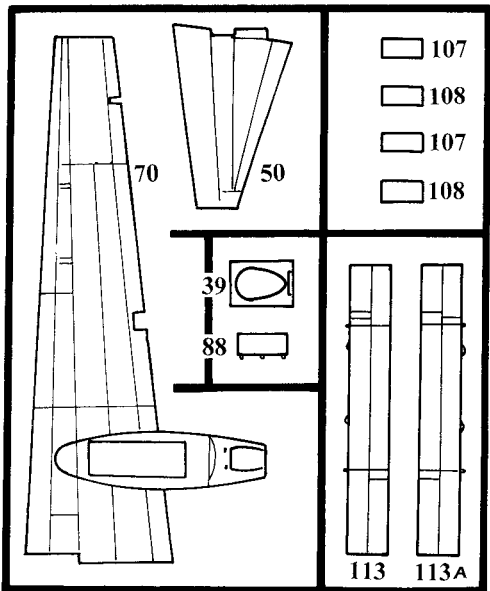
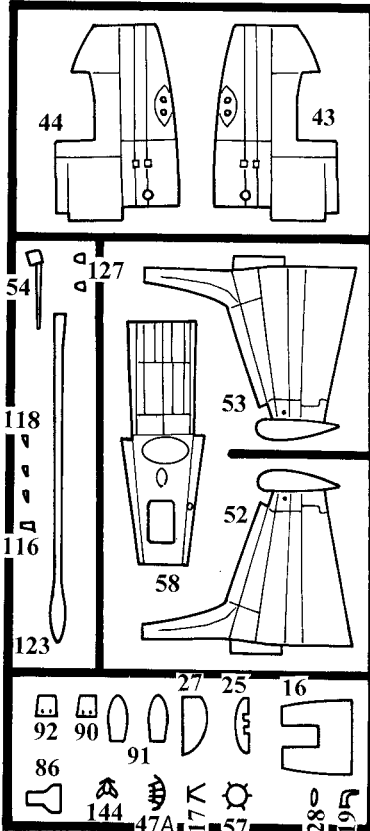
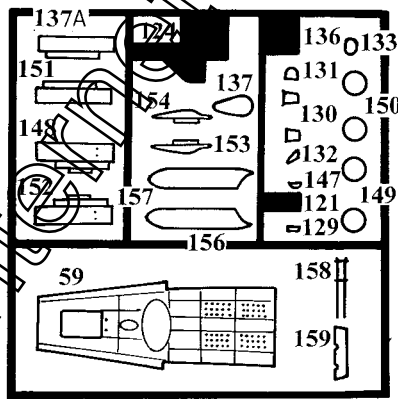
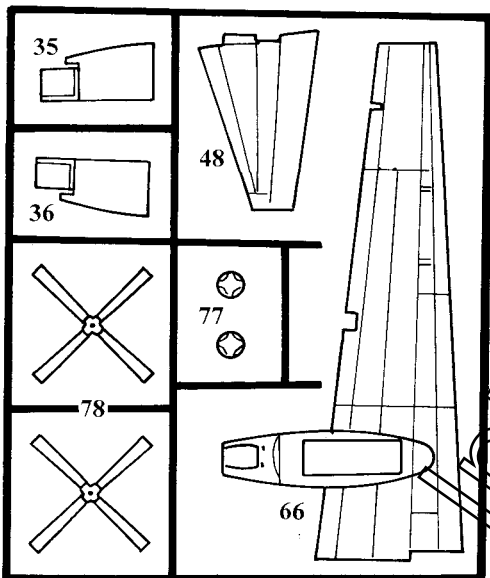
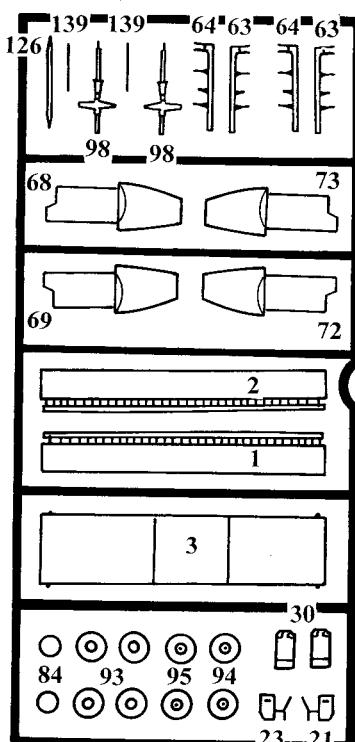
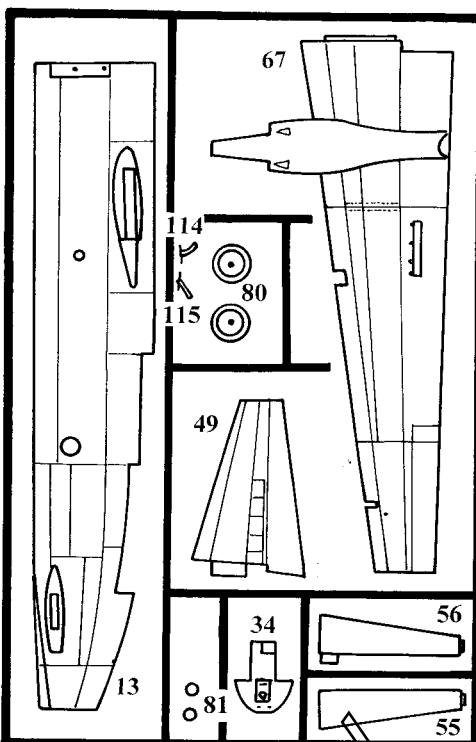
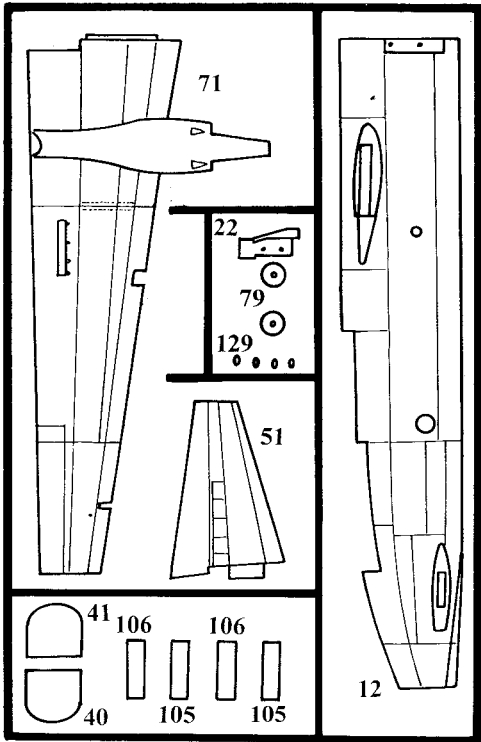

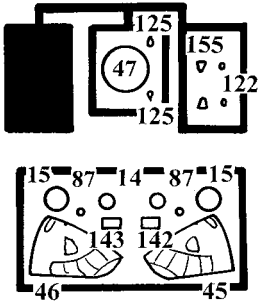

Nicht benötigte Teile
 Parts not used
 Pièces non utilisées
 Niet benodigde onderdelen
 Peças não utilizadas
 Parti non usate
 Inte använda delar
 Tarpeetomat osat
 Ikke nødvendige dele
 Deler som ikke er nødvendige
 Ηλεκαισσωσιμιας δεταρια
 Elementy niepotrzebne
 Gereksiz parçalar
 Nepotrebné diely
 fel nem használt alkatrészek
 Nepotrebni deli

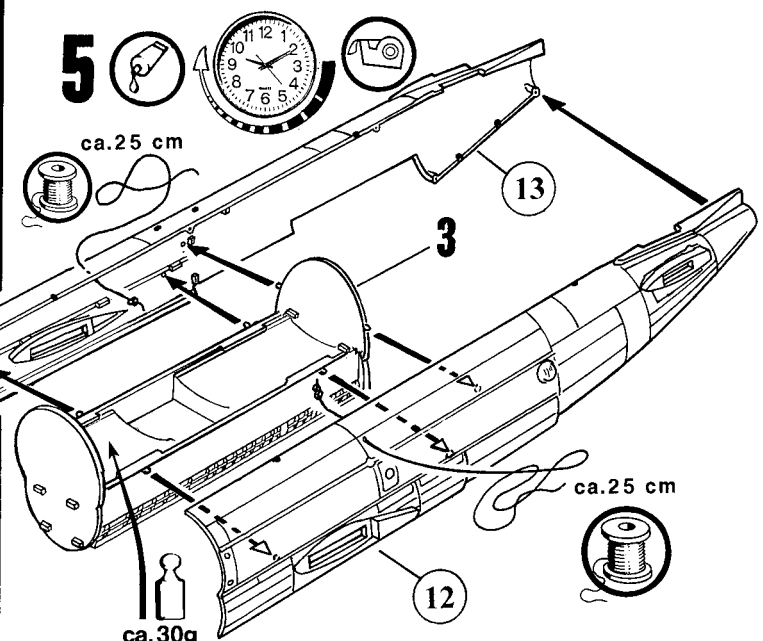
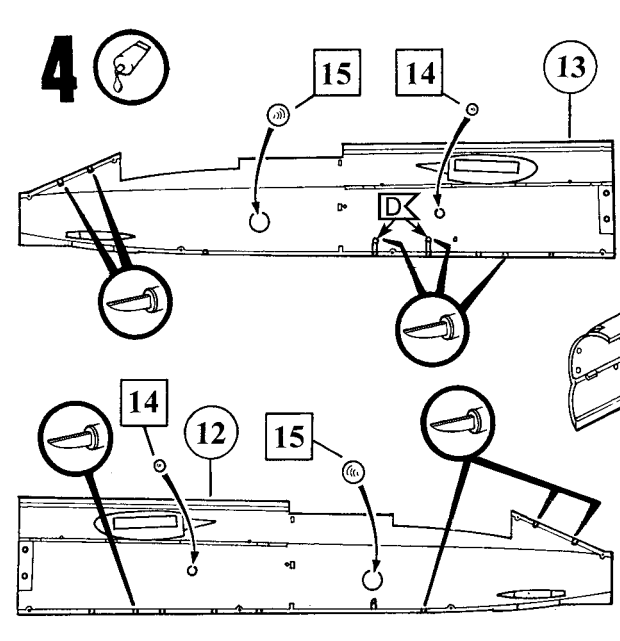
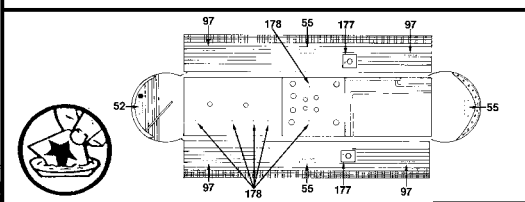
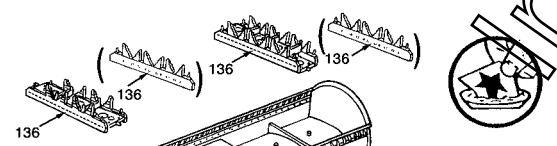
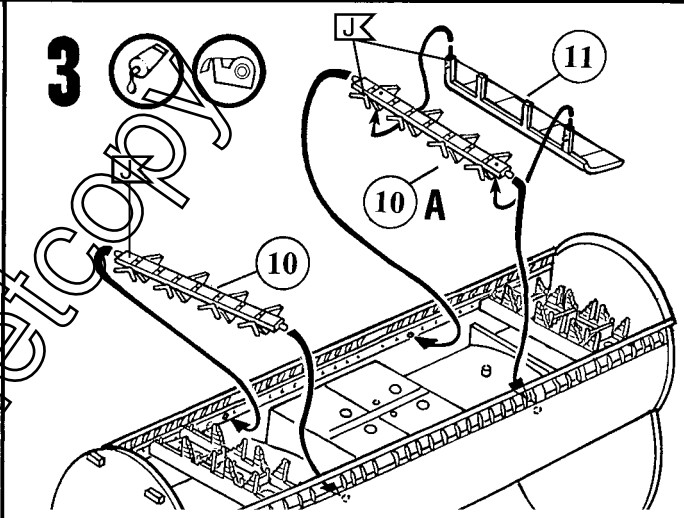
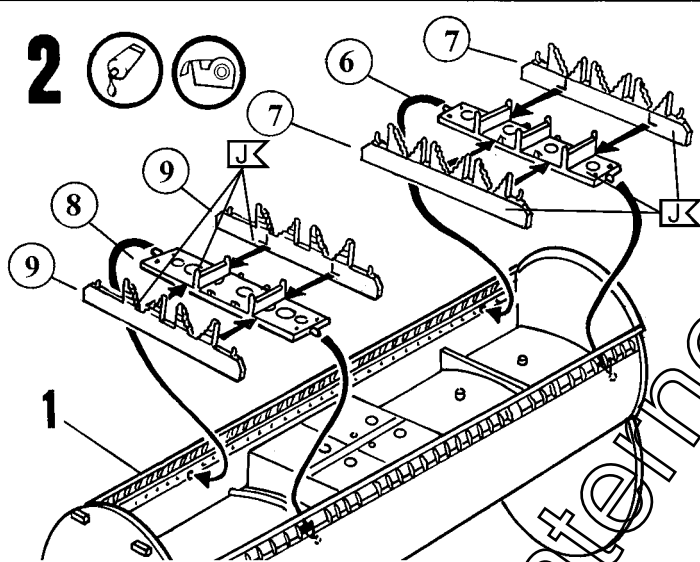
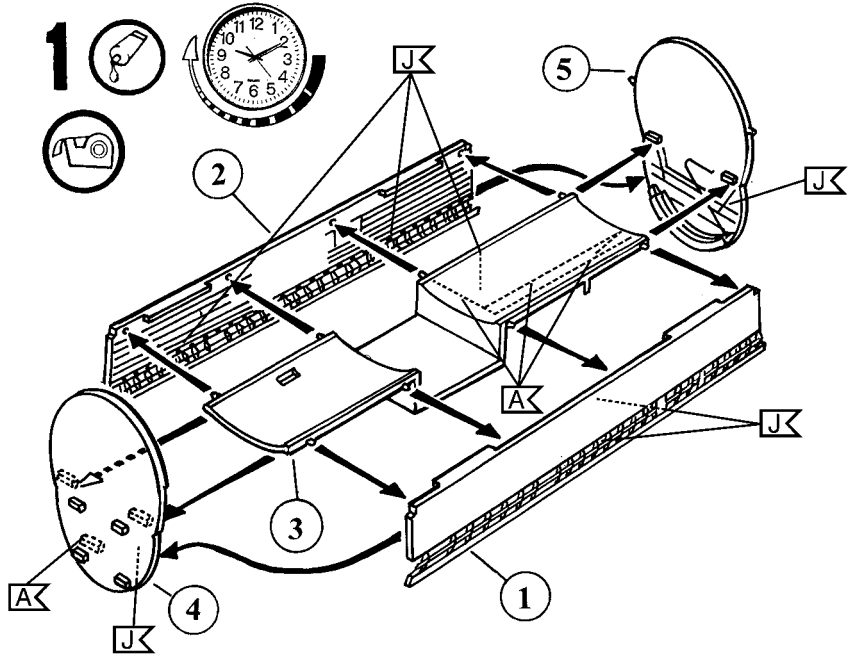

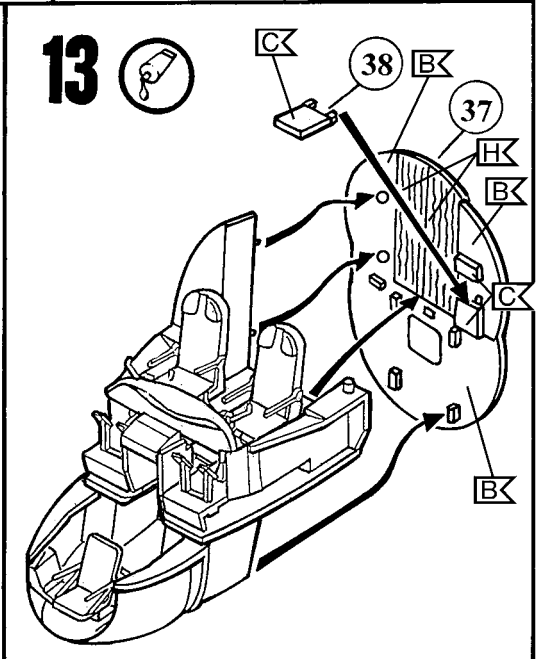
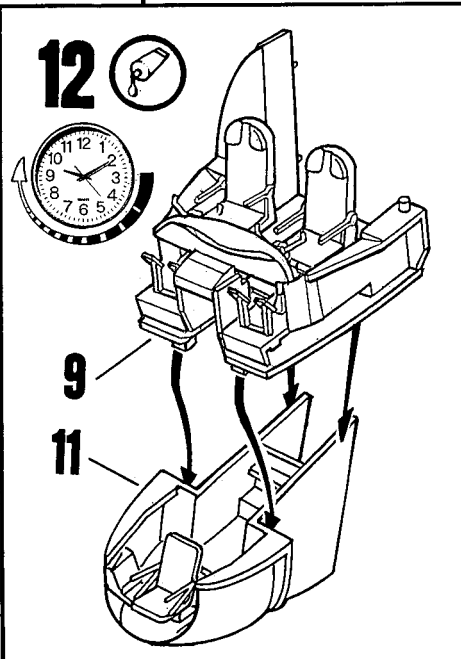
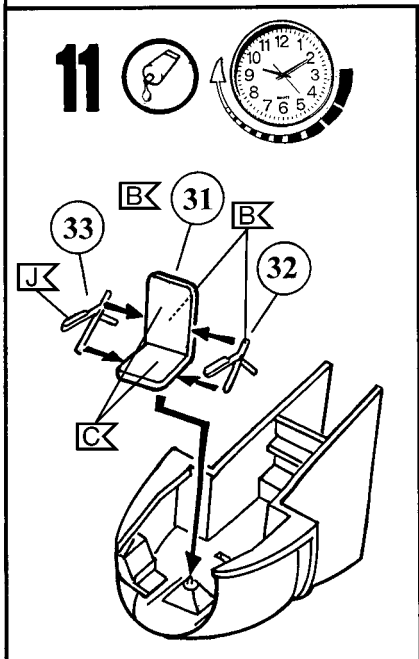
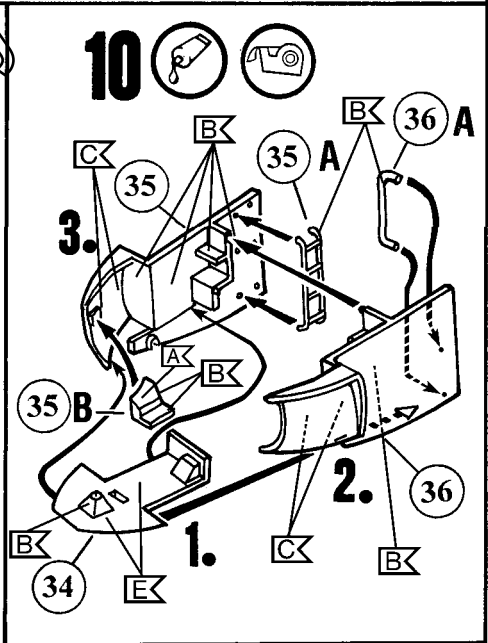
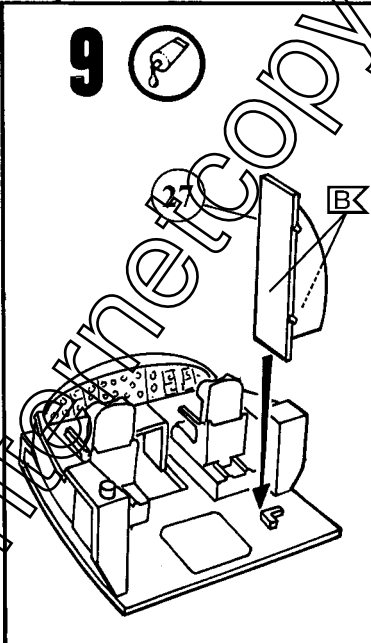
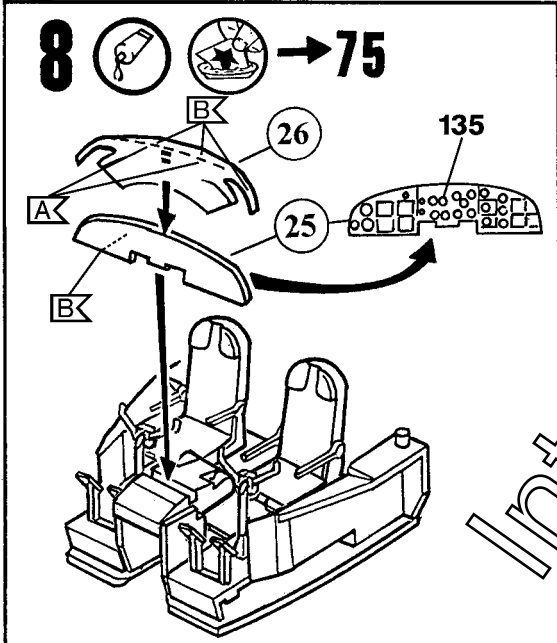
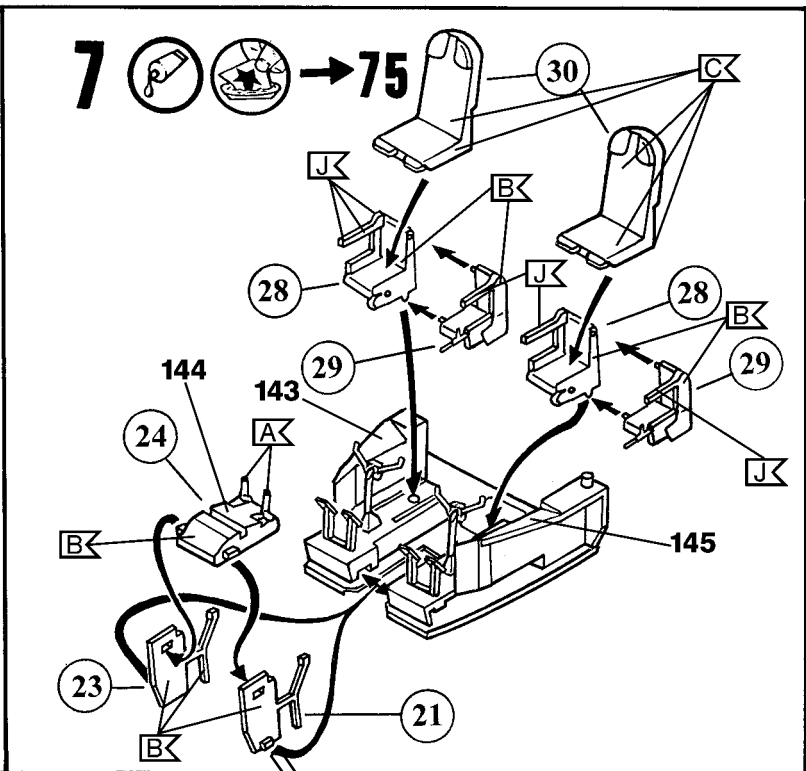
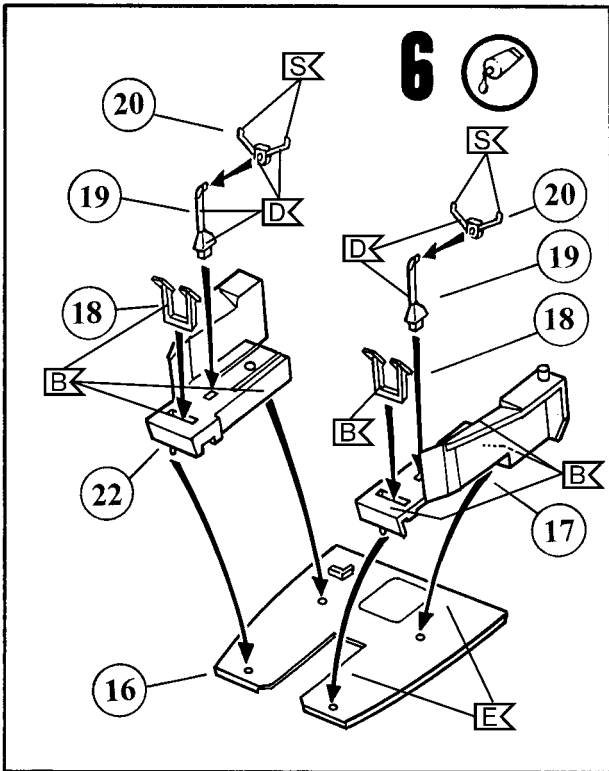

14 

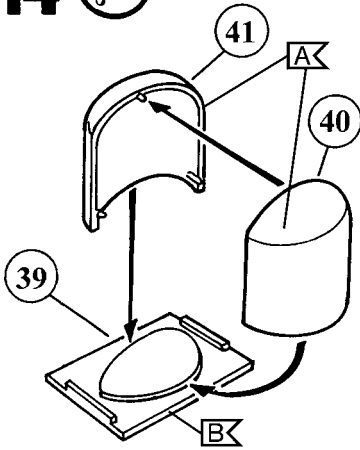

15 

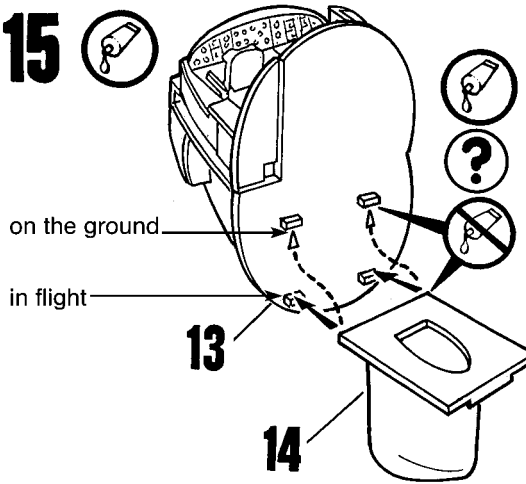

16 

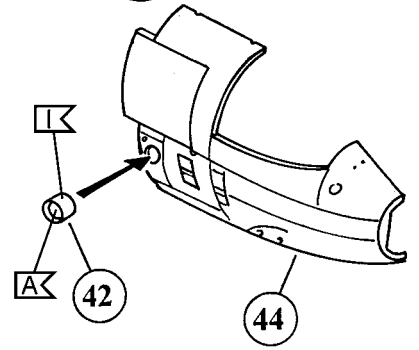

17  

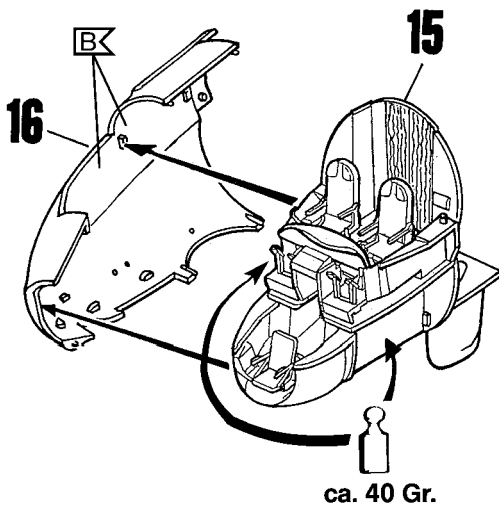

18  

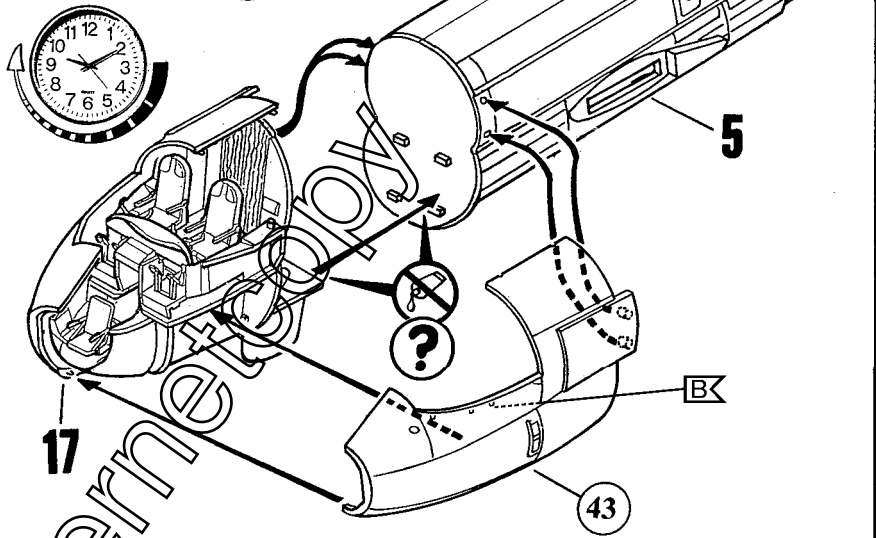

19   

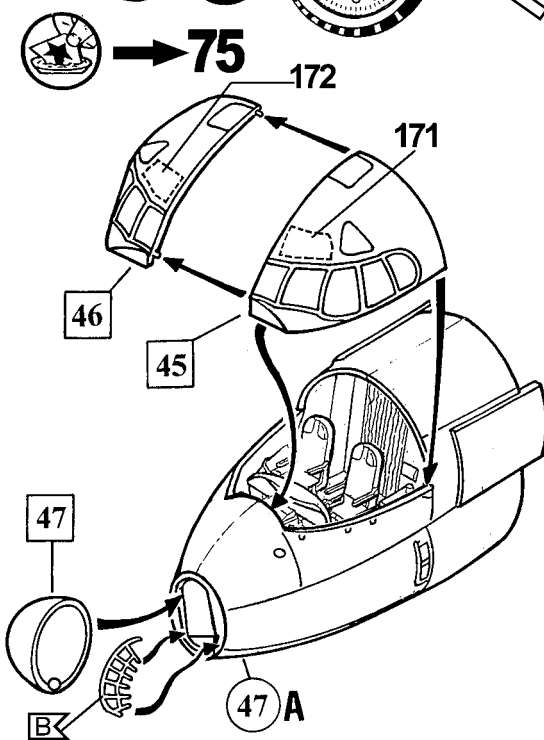

20  

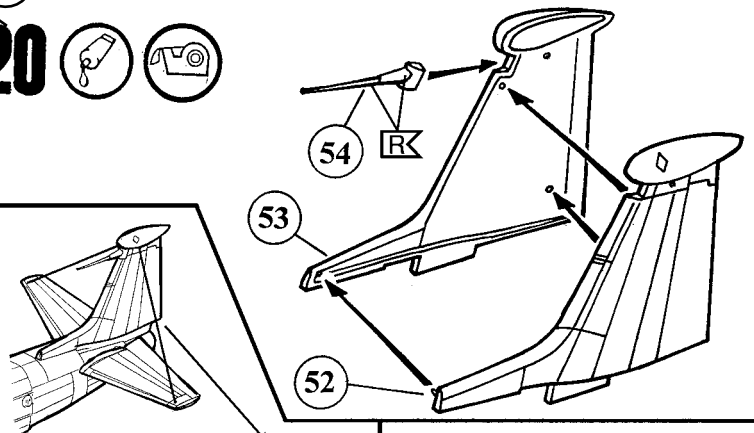

21  

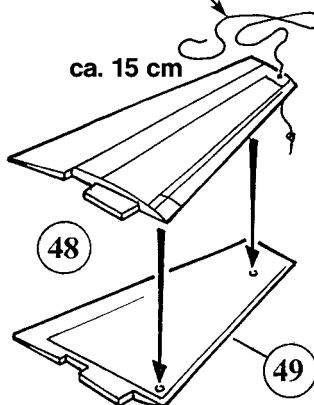

22  

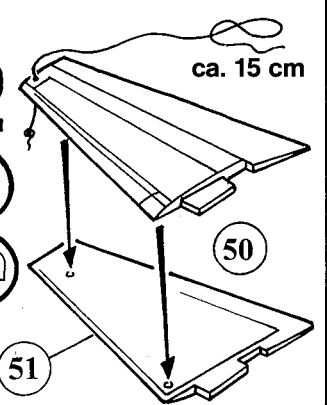

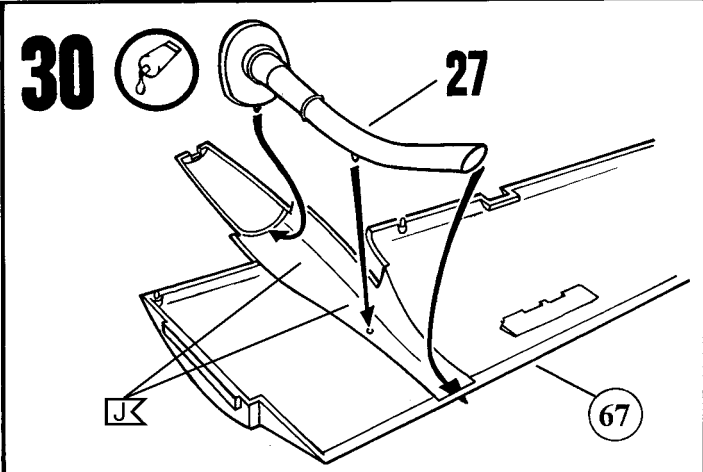
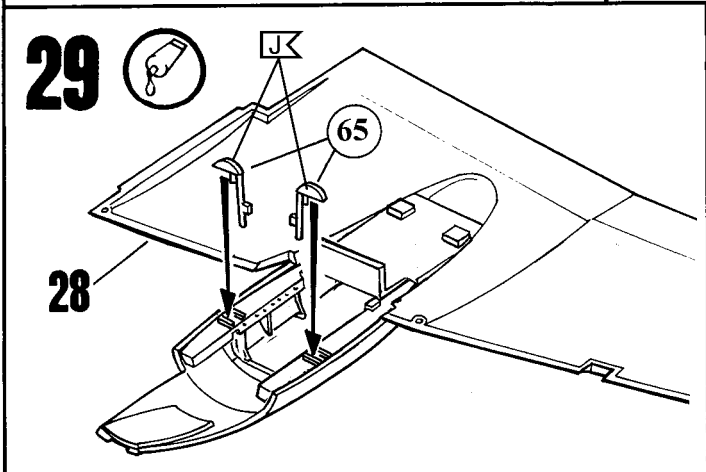
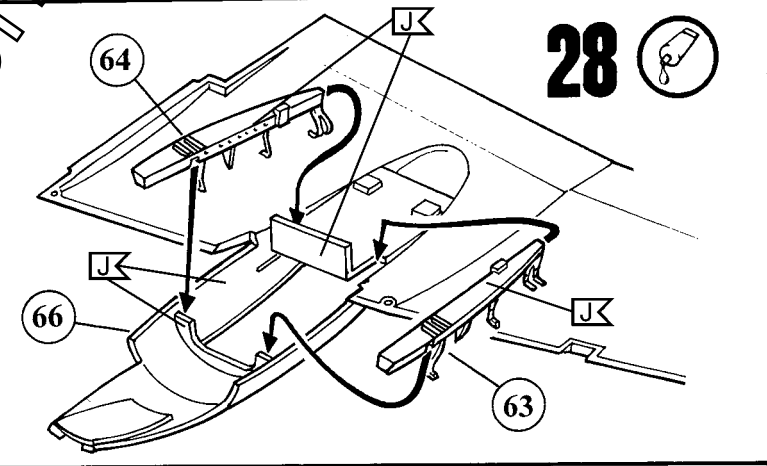
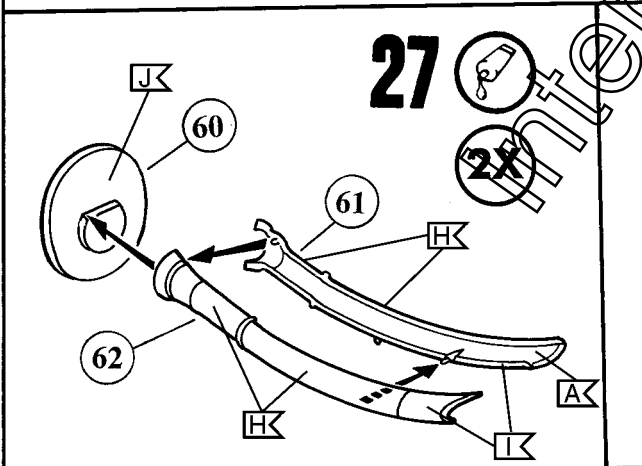
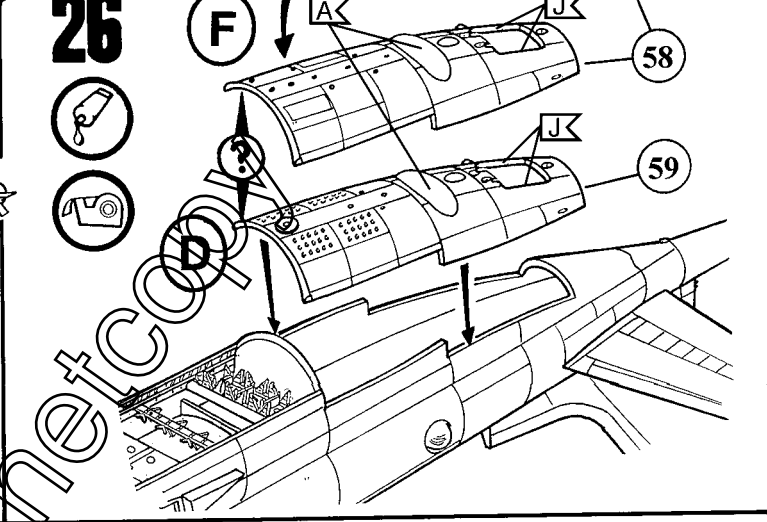
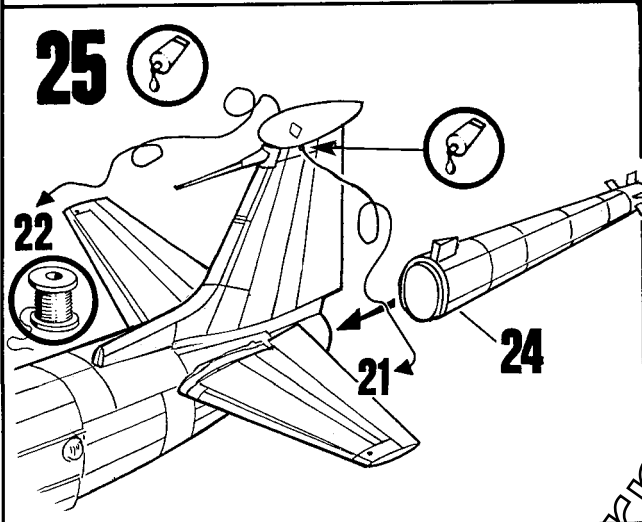
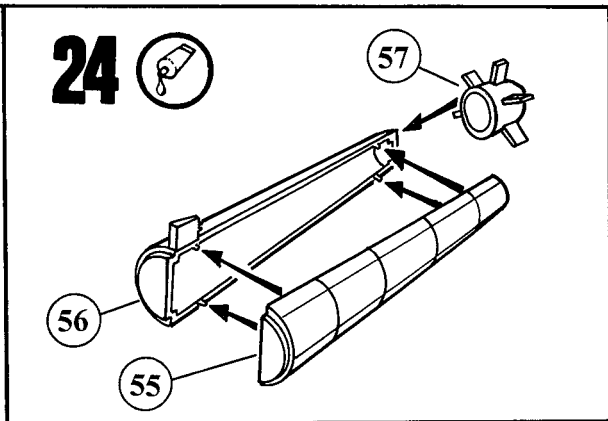
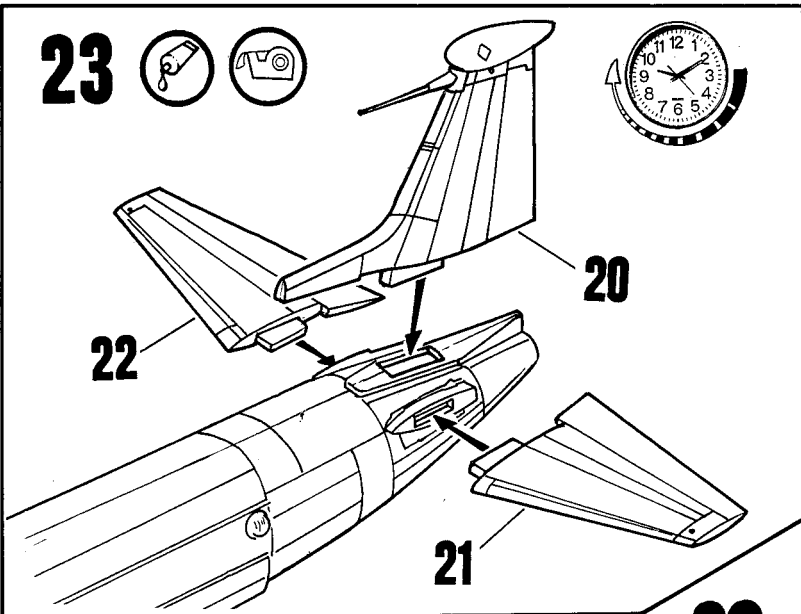

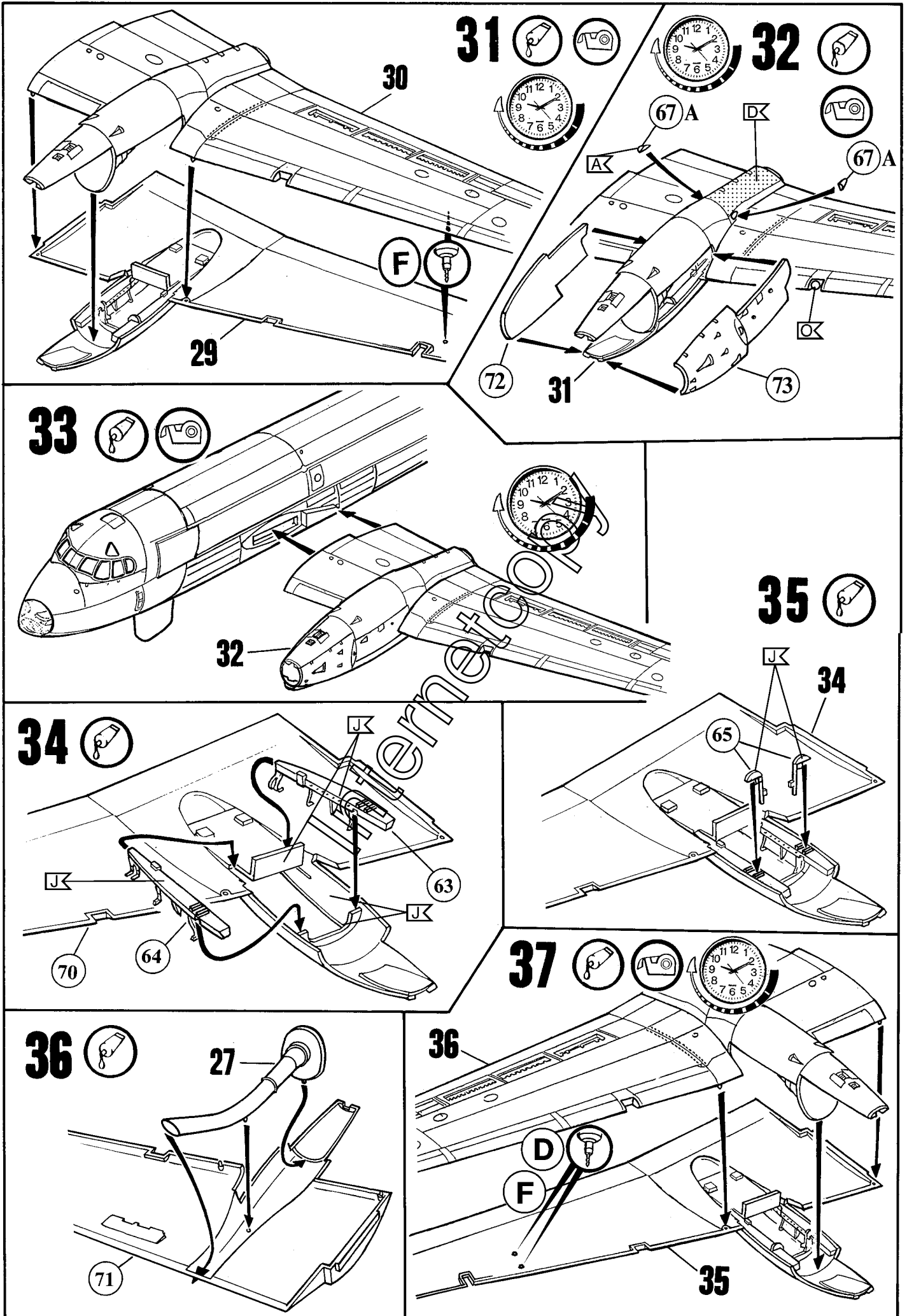

38

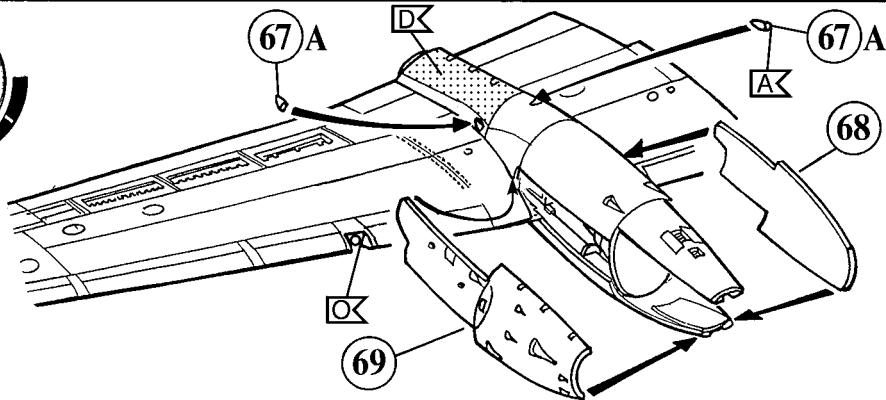

39

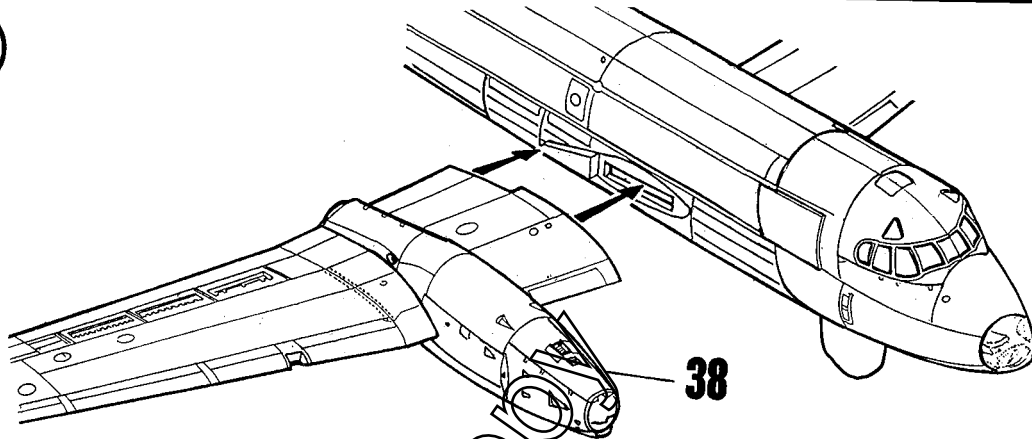

40

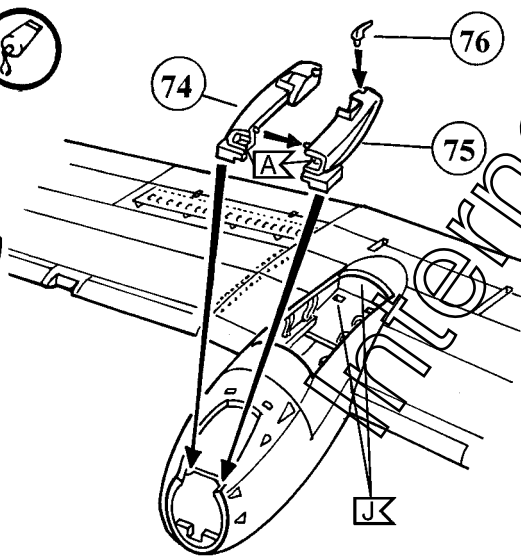

41

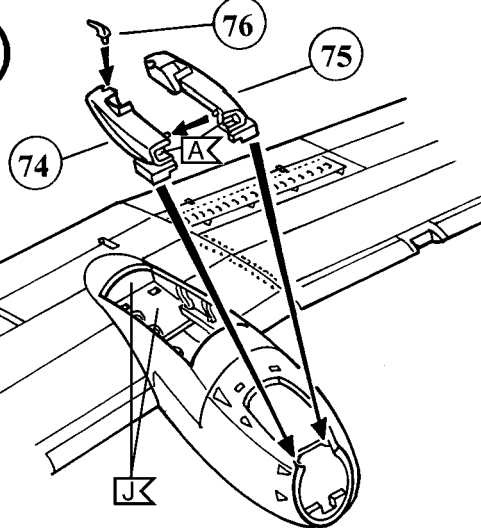

42

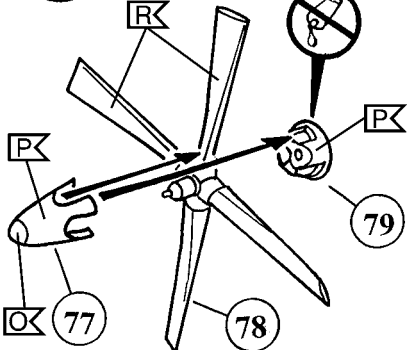

42A

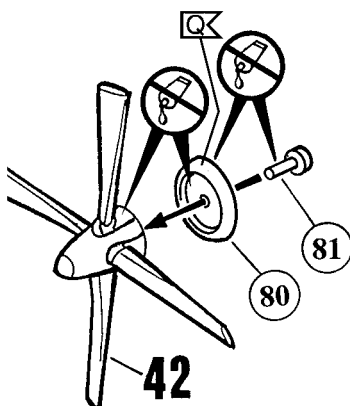

43

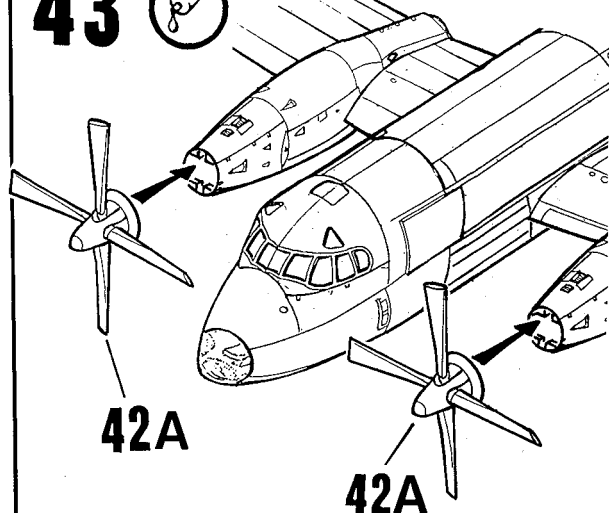

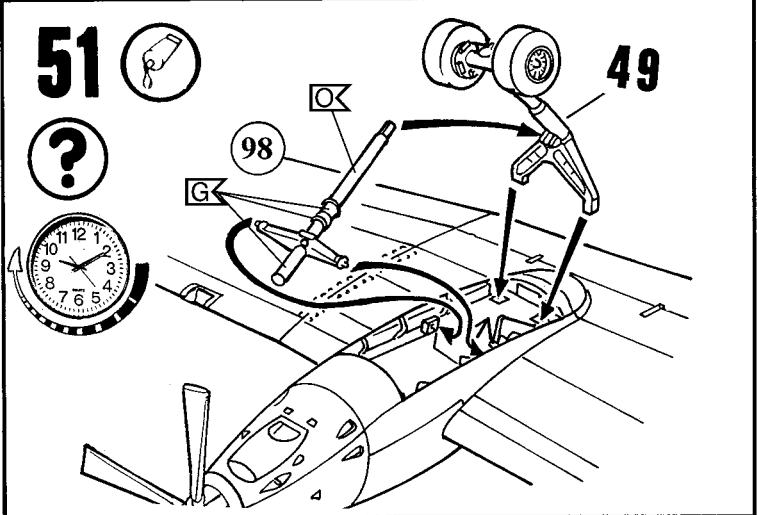
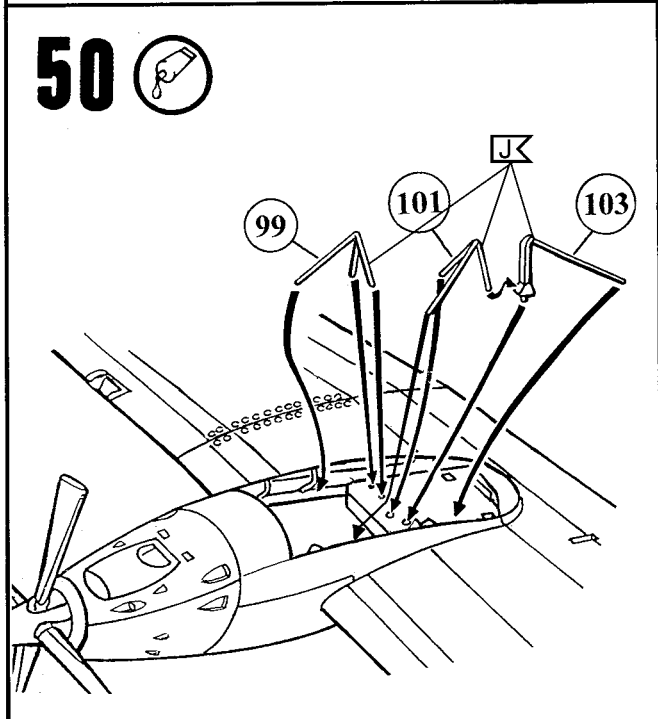
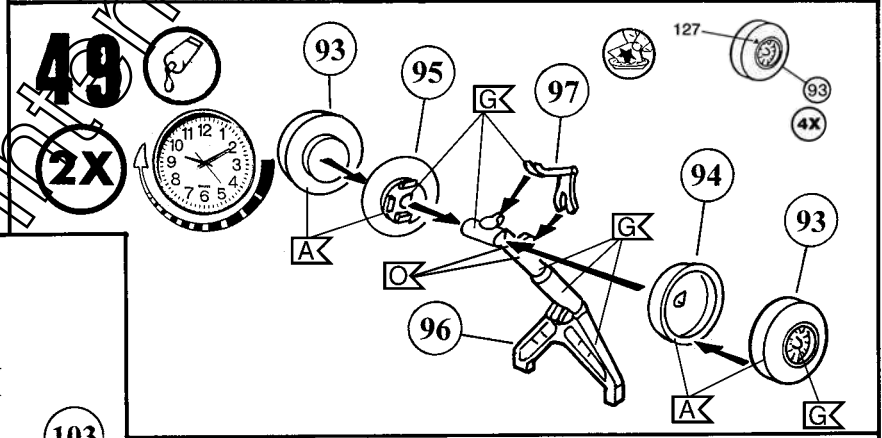
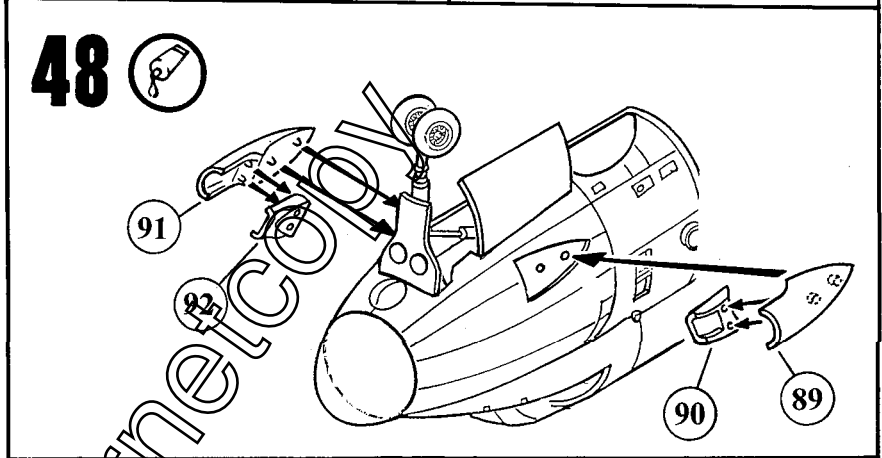
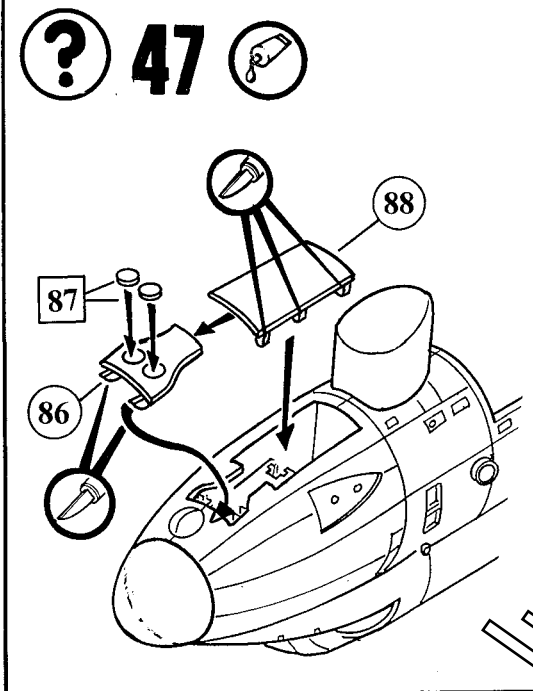
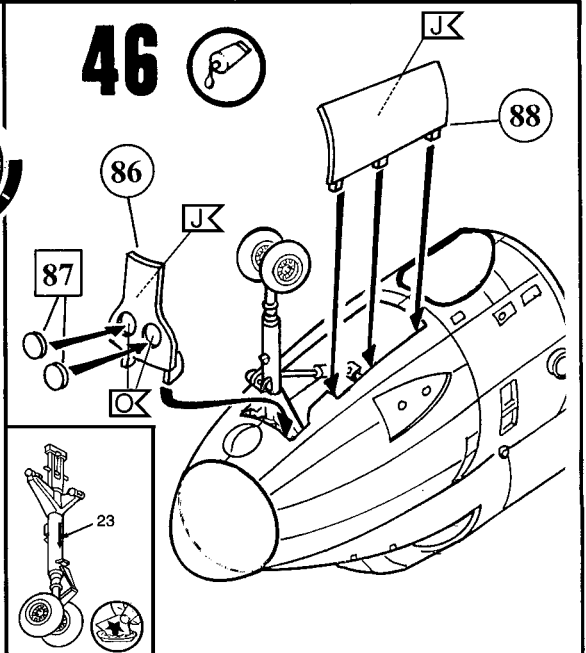
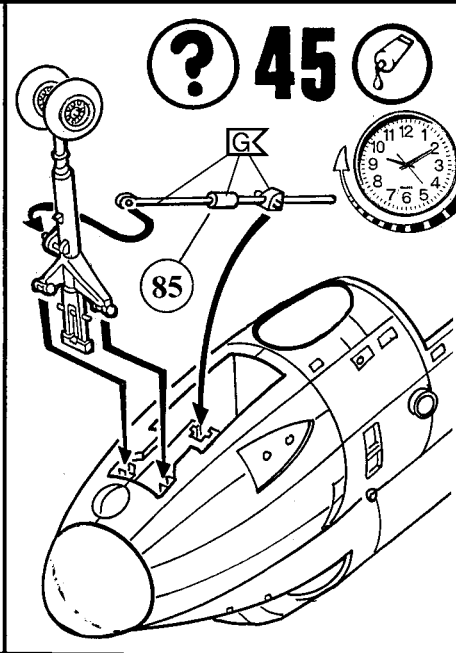
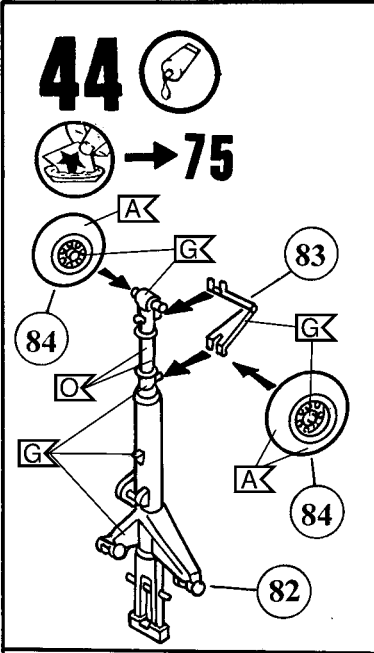

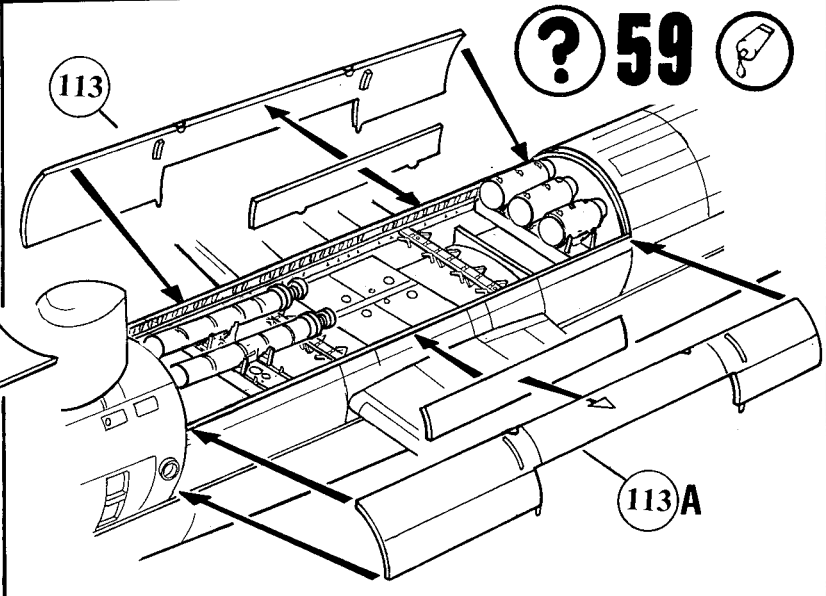
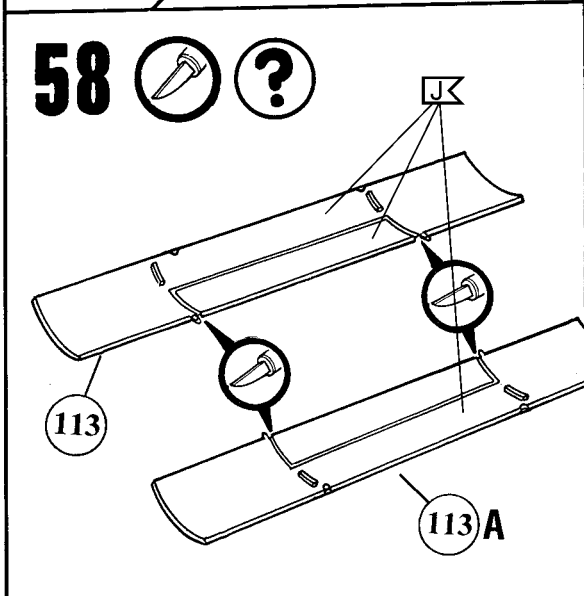
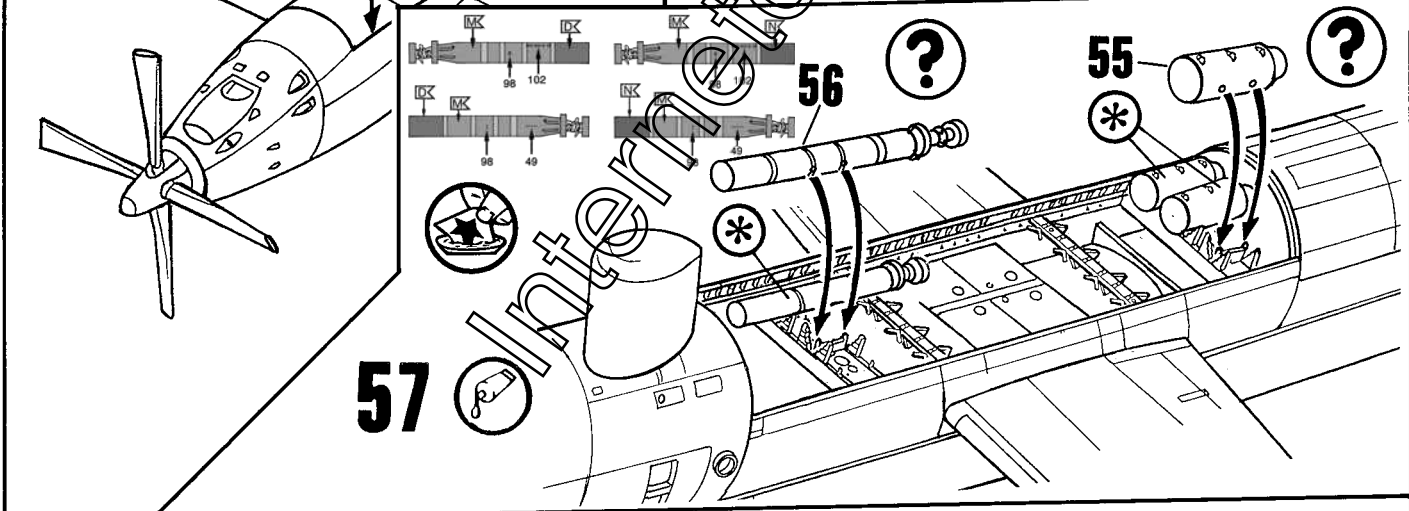
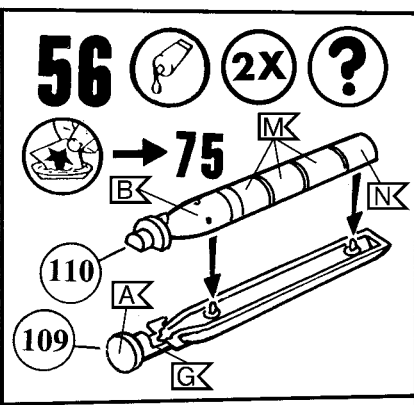
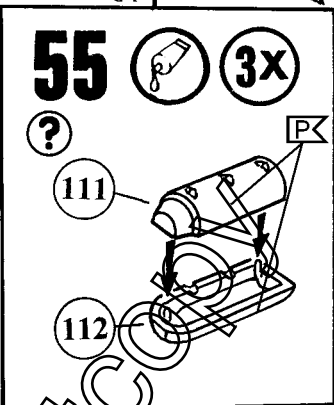
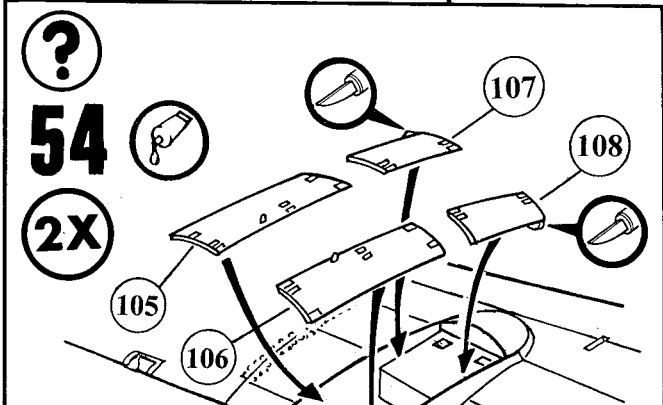
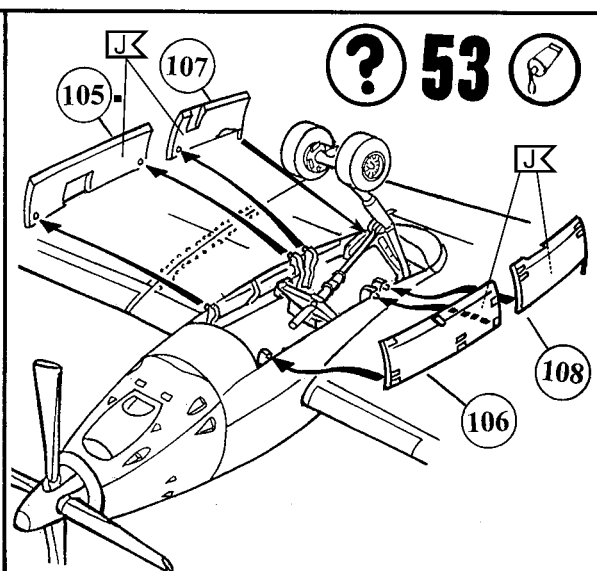
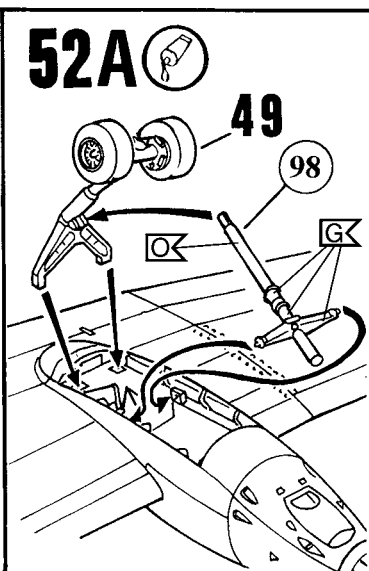
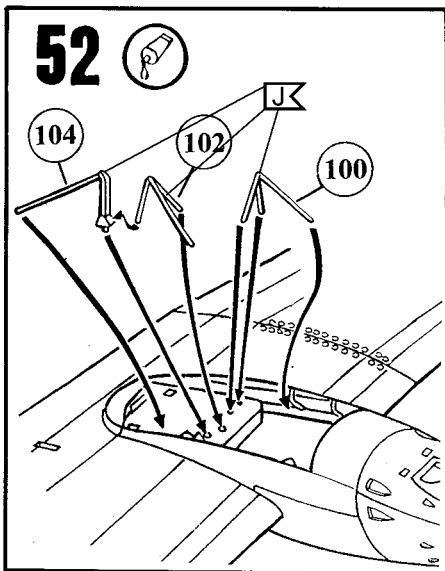

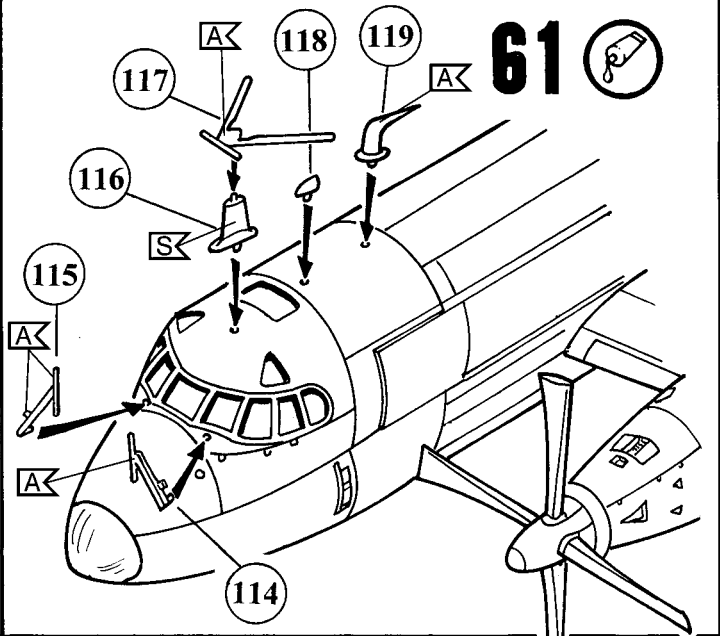
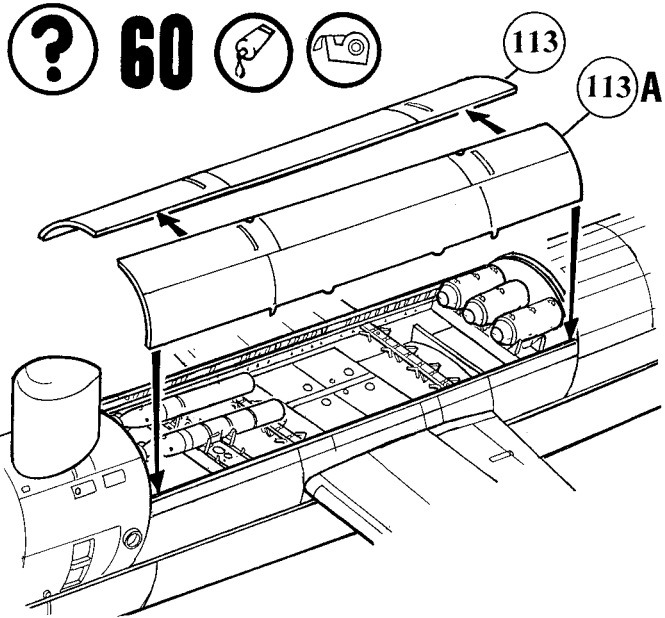

62 

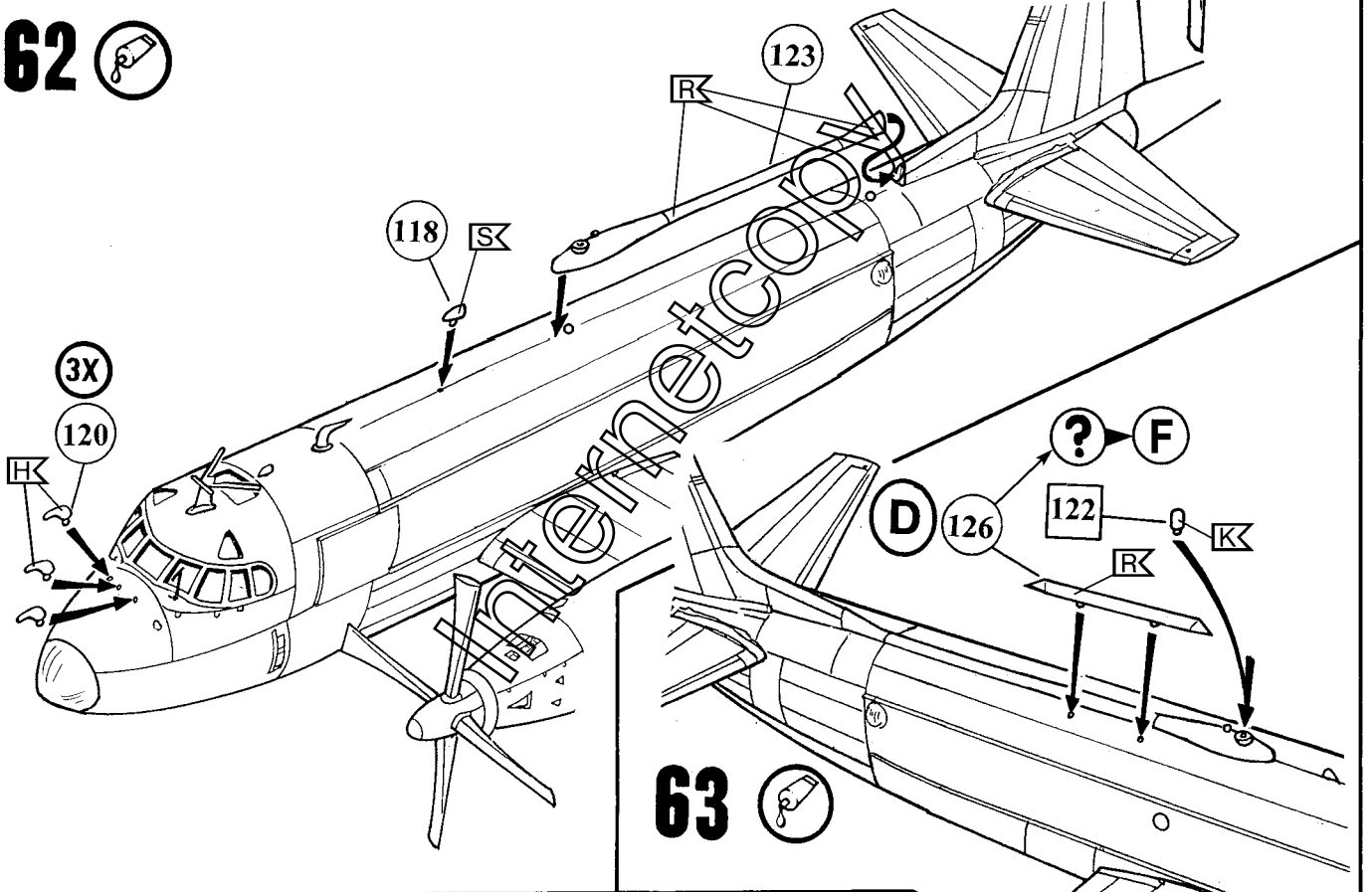

63 

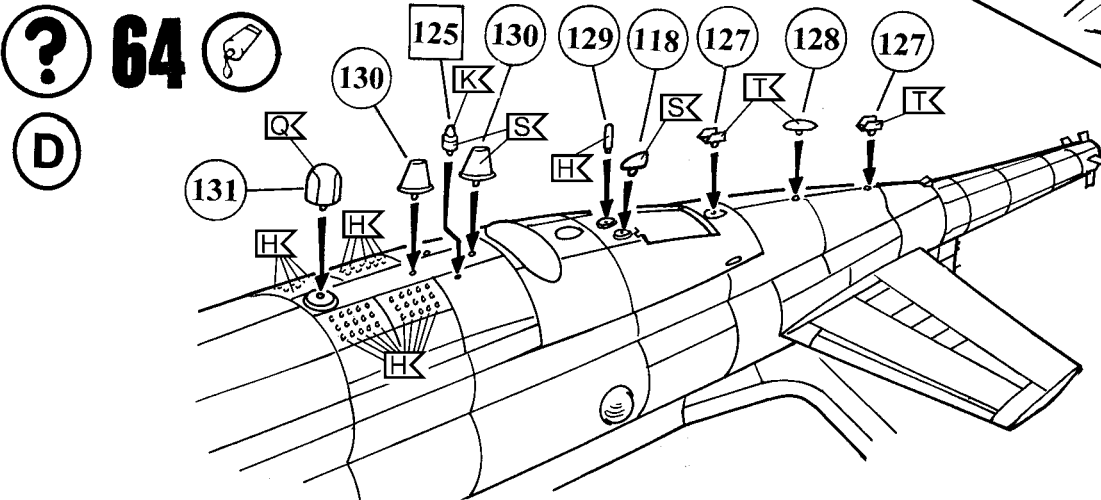

? 65 

NL

F

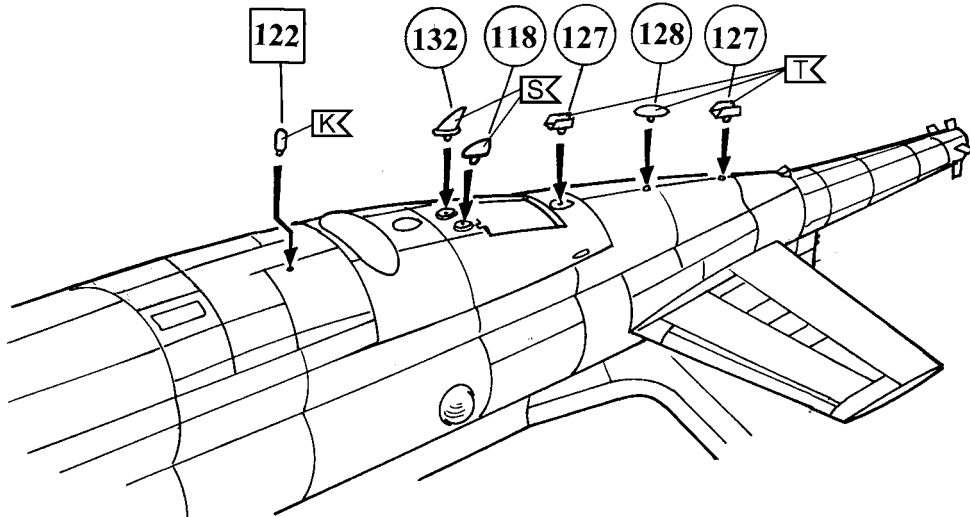

NL F ? 66 

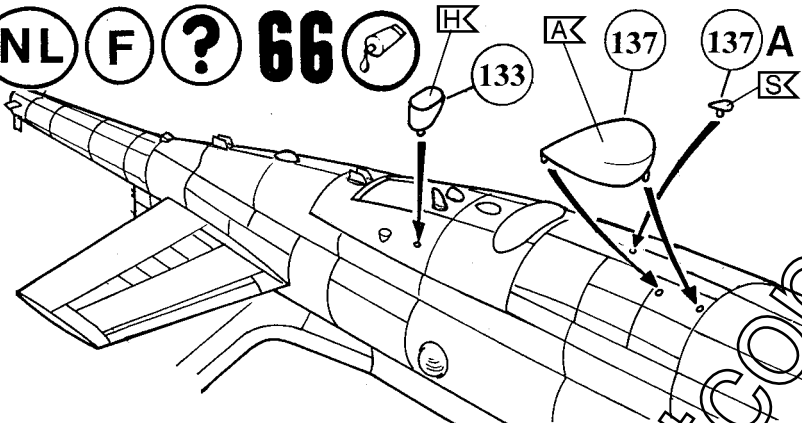

67 

?

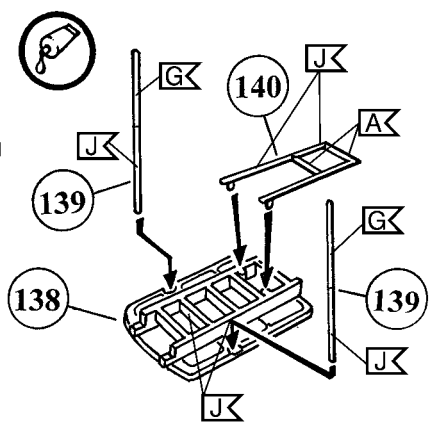

68 

?

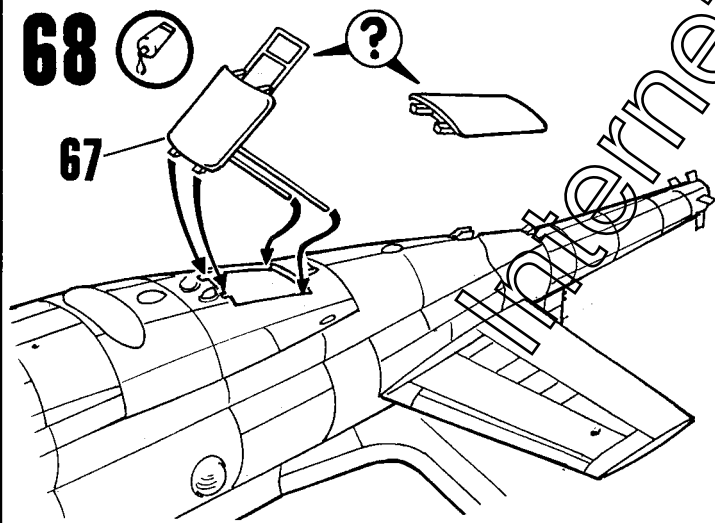

D ?

69 

75, 76

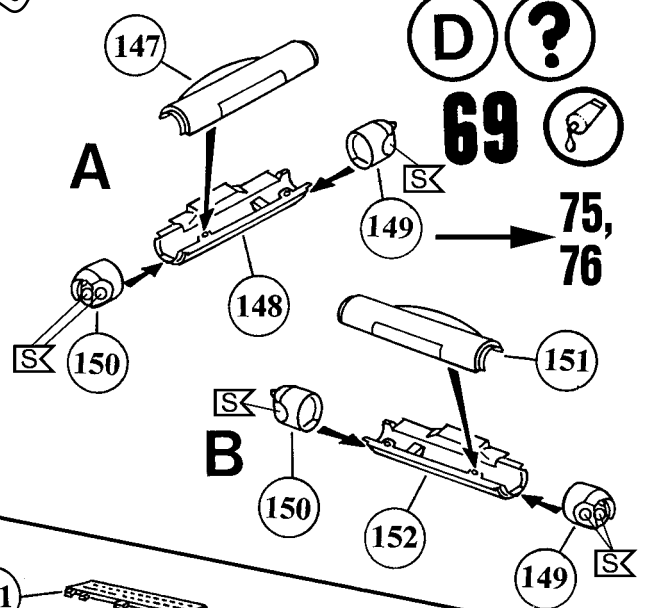

70 

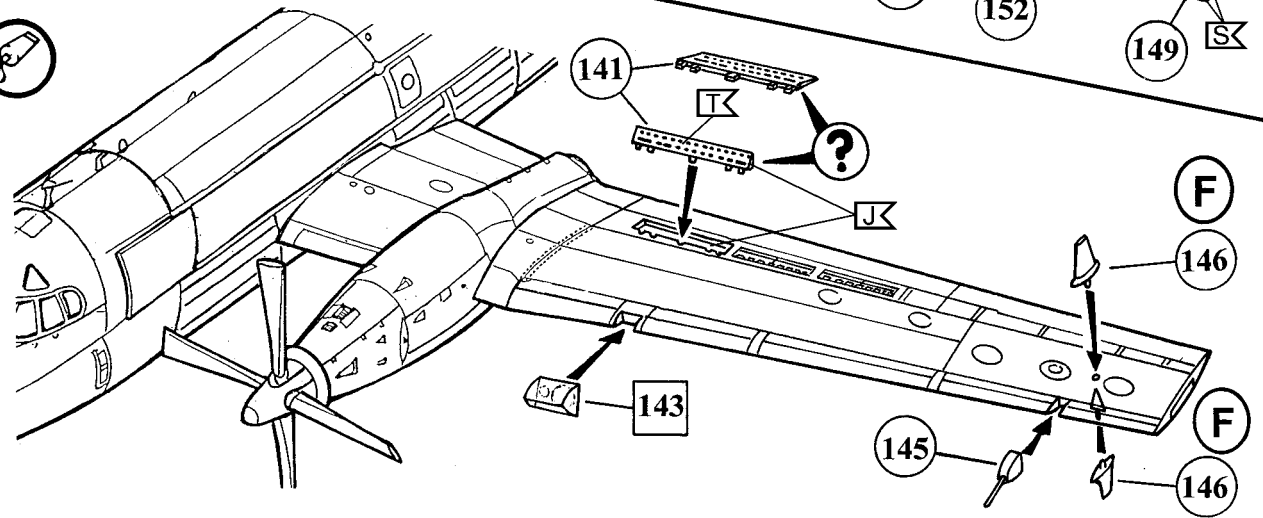

F

146

F

146

71

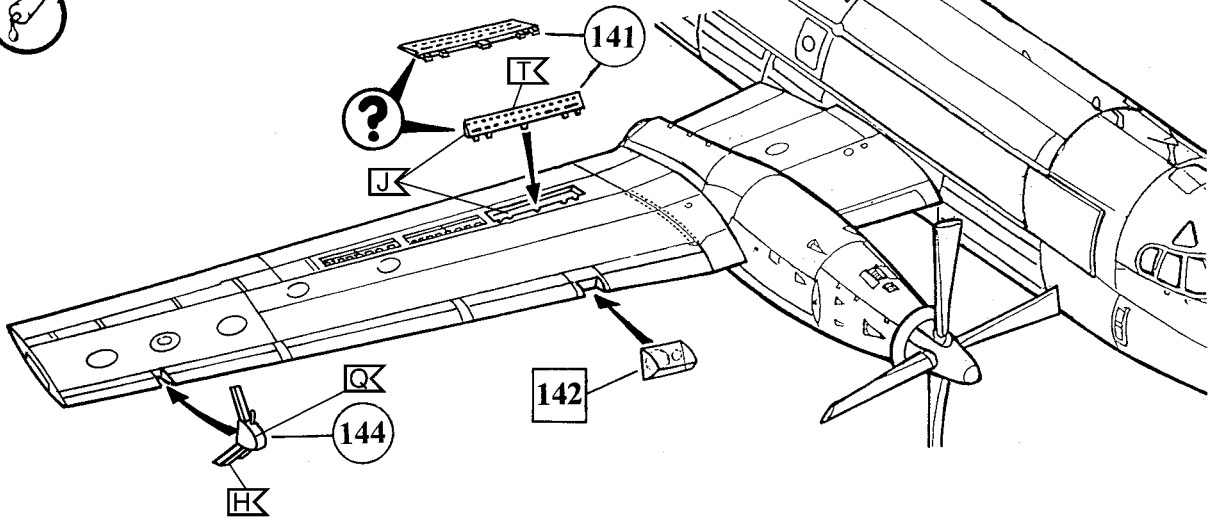

72

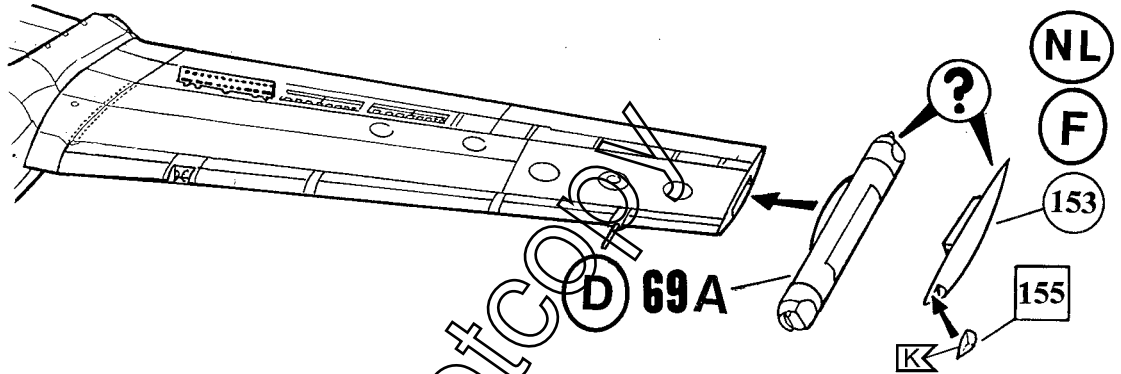

73

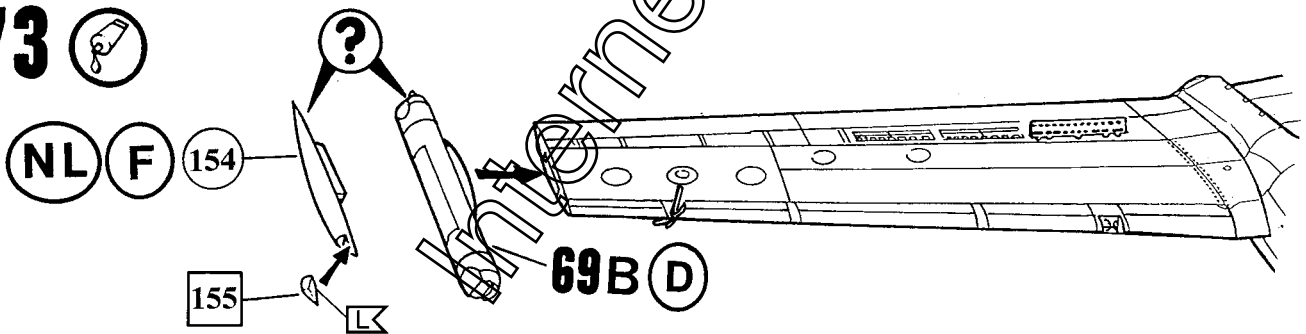

74

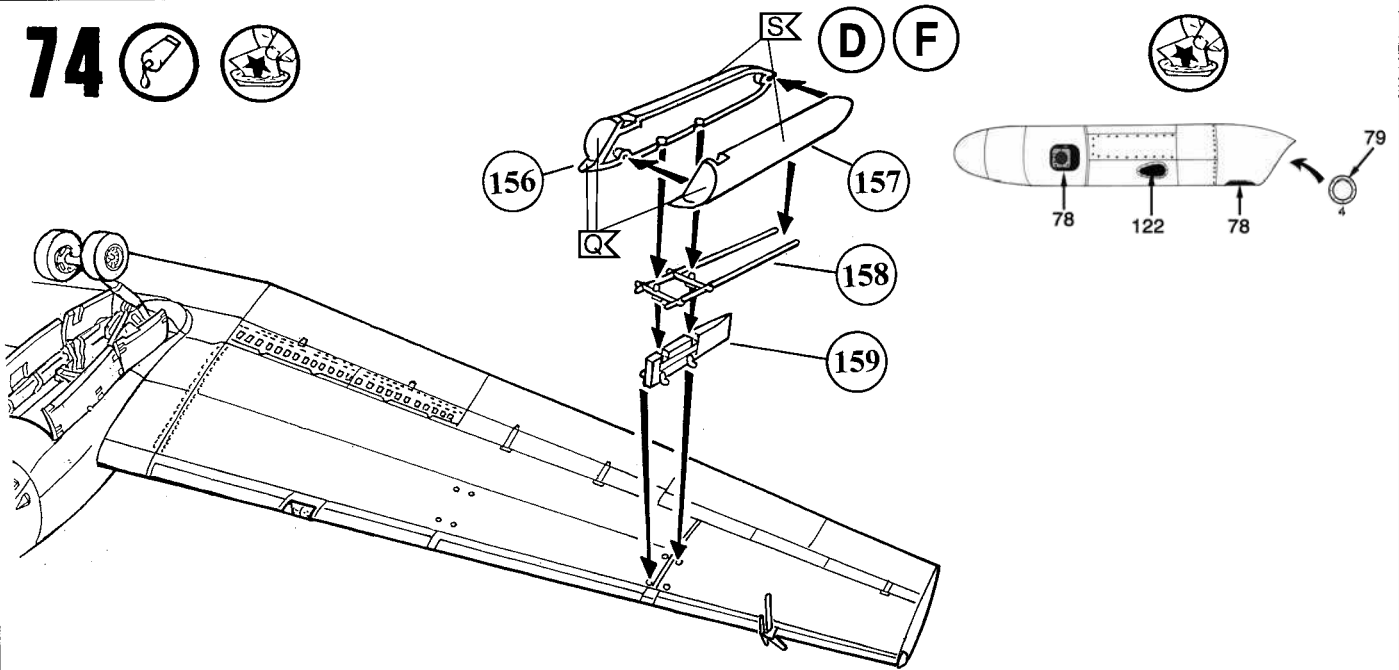

75



Breguet Br.1150 Atlantic of
Marineflieger Geschwader 3 - MFG 3 -
Anniversary „50 Jahre Marine“
Nordholz 2006

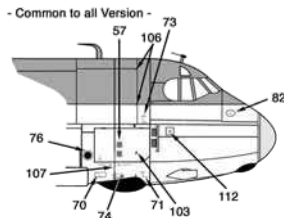
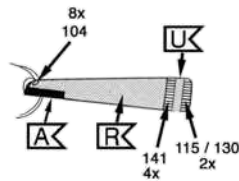
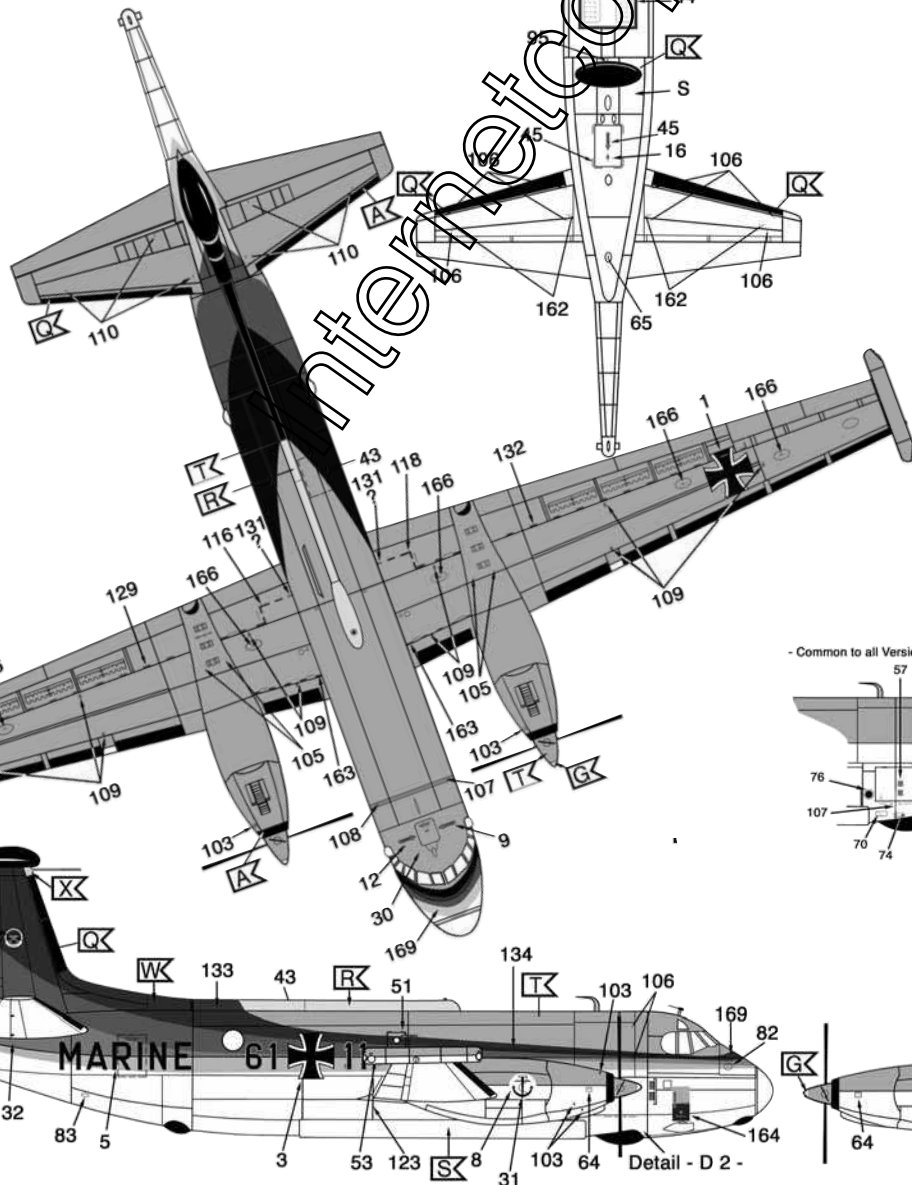
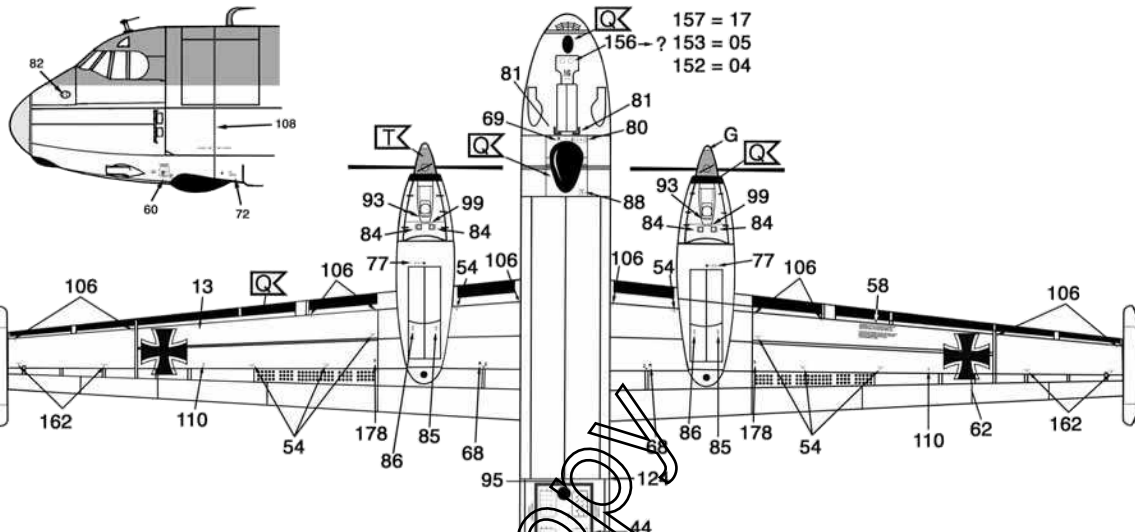
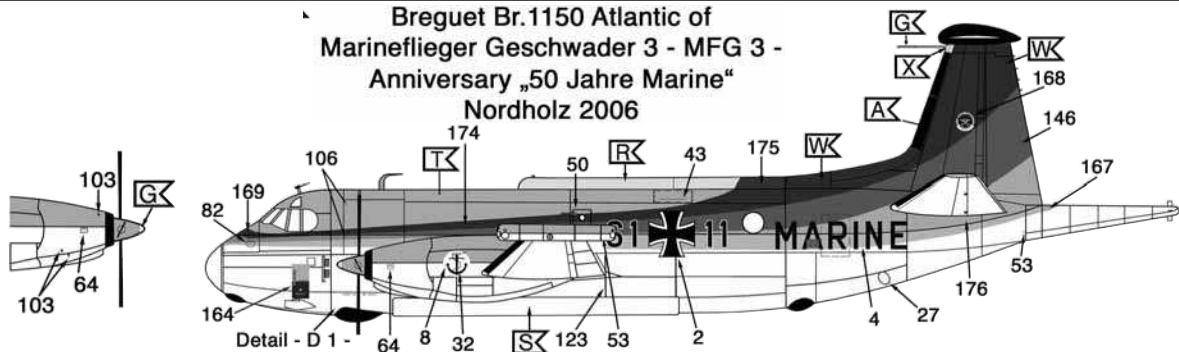

76



Breguet Br.1150 Atlantic of Marineflieger Geschwader 3 - MFG 3 - at Nordholz, May 1985

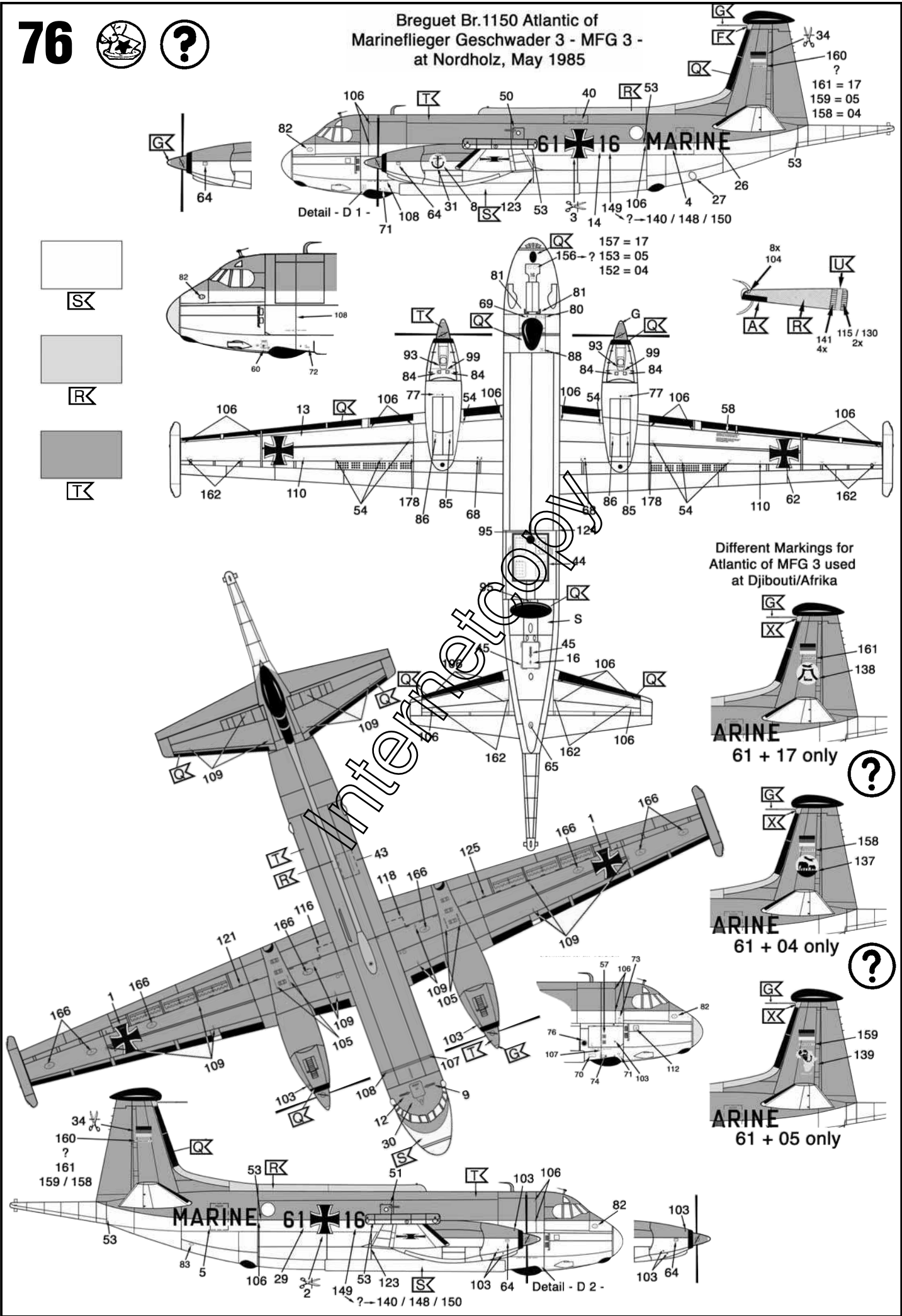

77



Breguet Br. 1150 Atlantic
Aeronavale, Flotille 24F
BAN Lann-Bihoué,
Anniversary of „First Flight“

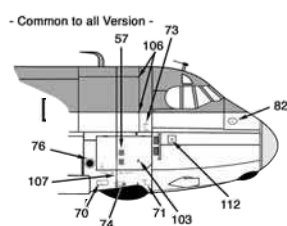
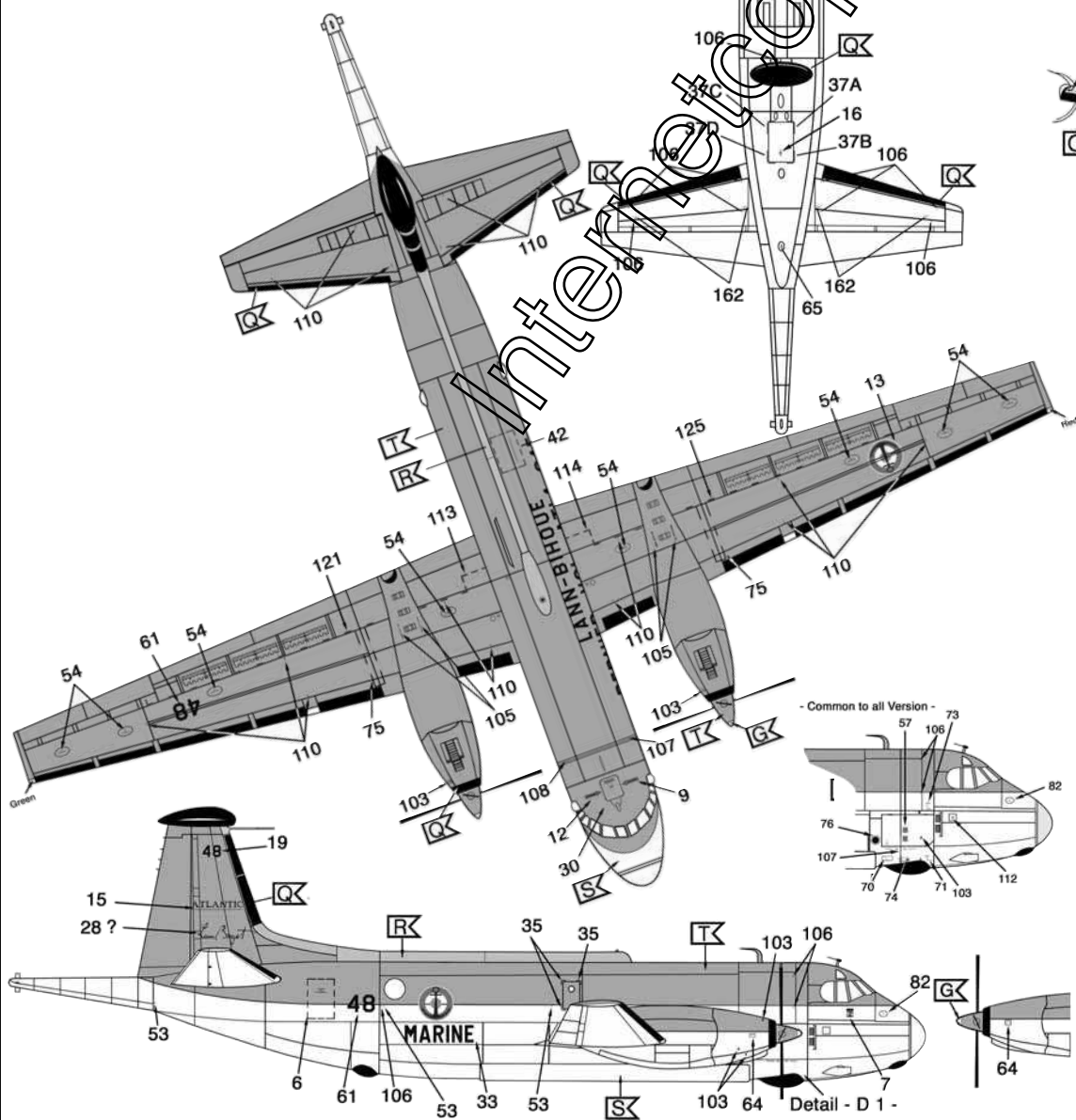
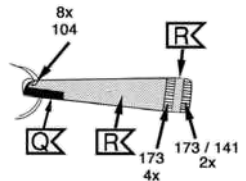
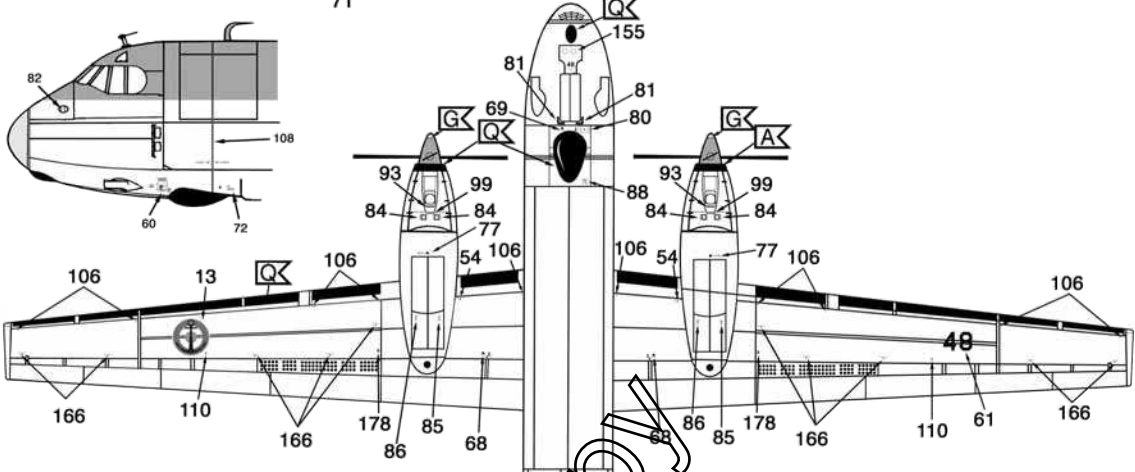
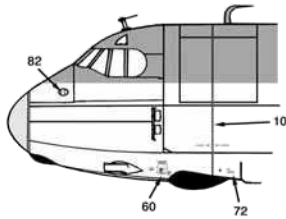
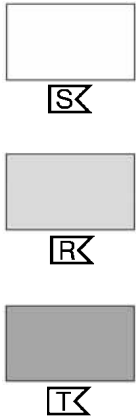
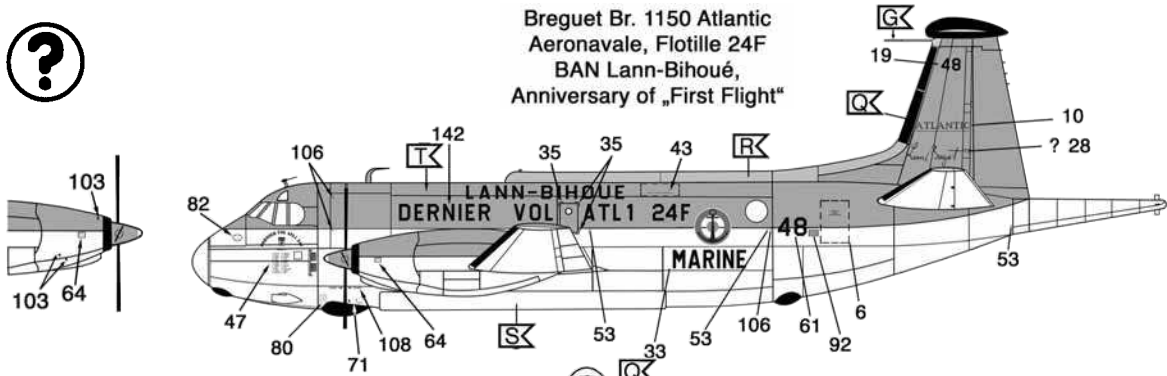

78



Breguet Br. 1150 Atlantic of 320. Squadron Kon. Marine Netherland Valkenburg Netherland,

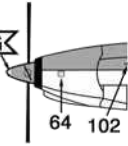
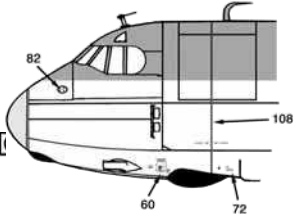
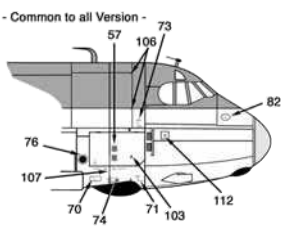
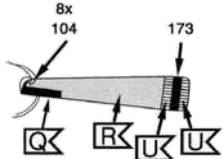
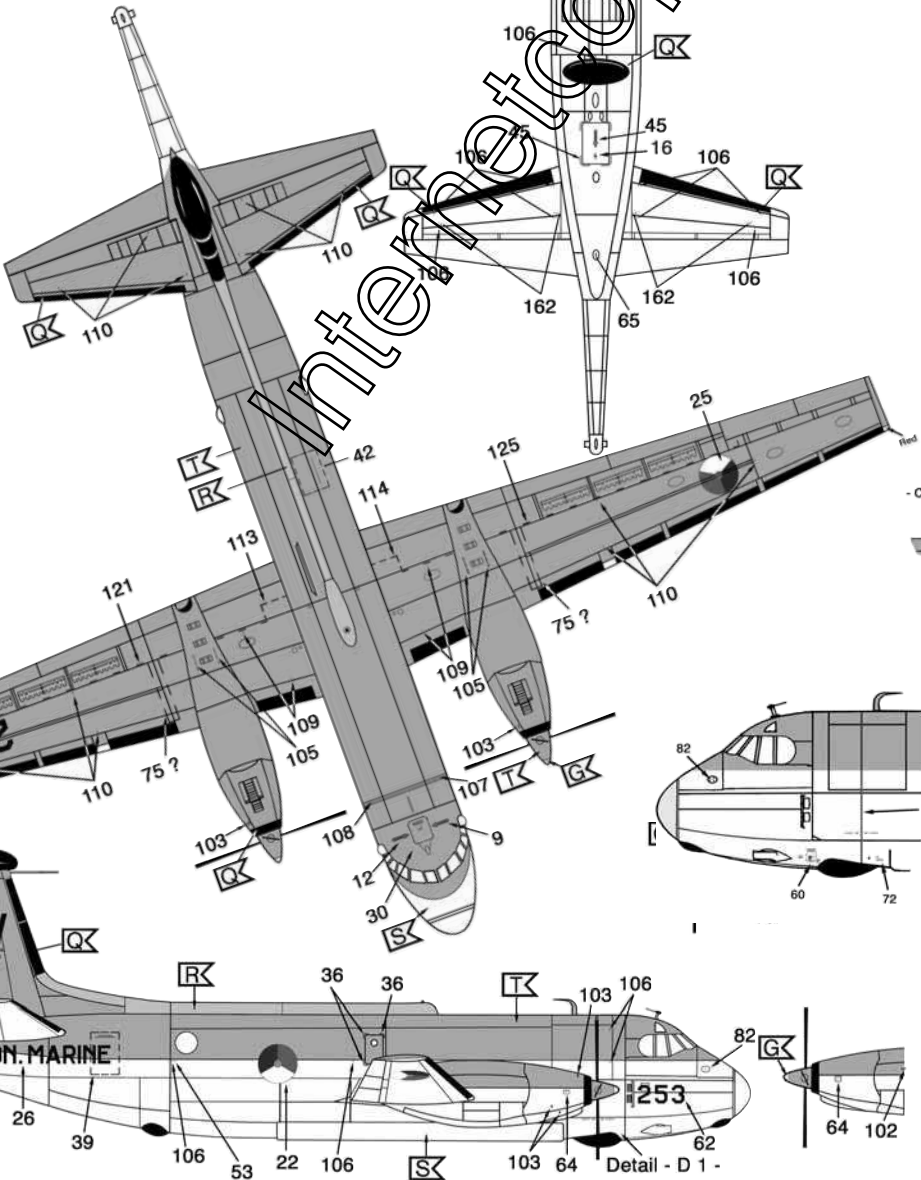
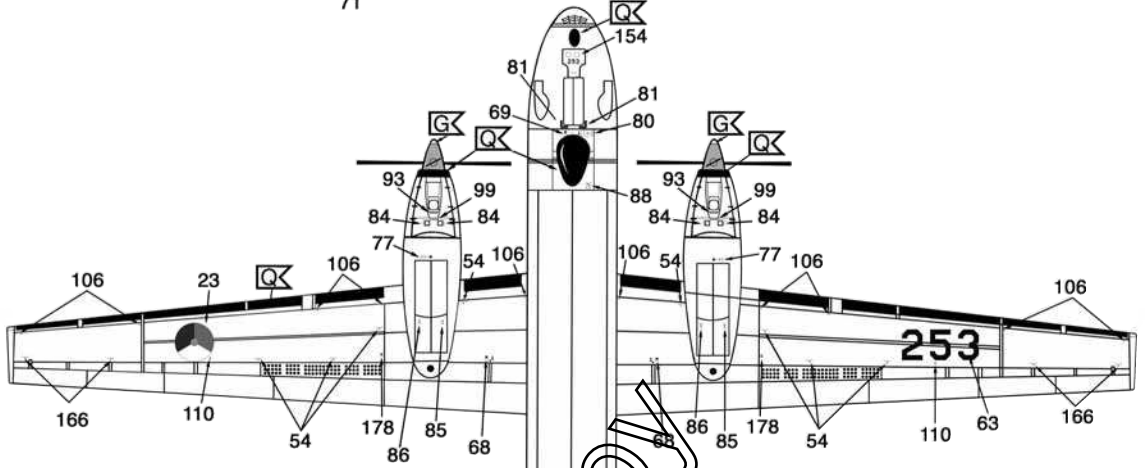
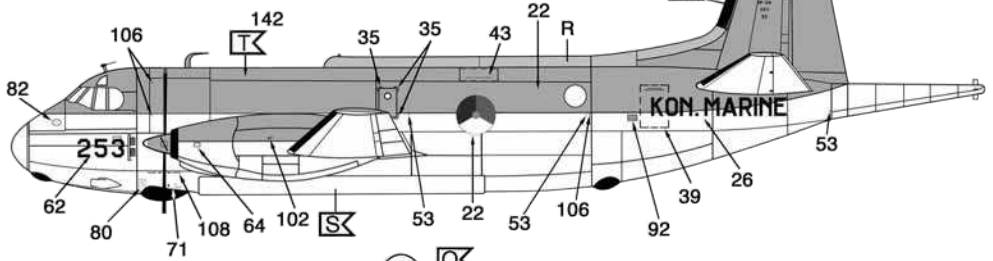
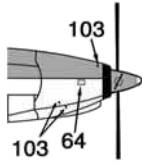
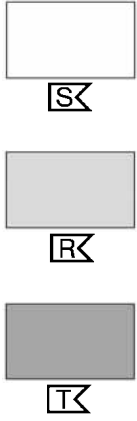

Detail - D 1 -